

WYLIE BRANCH UTILITIES

FOUR COUNTY ELECTRIC: 910-259-1860

PENDER COUNTY UTILITIES(WATER): 910-259-1570

PLURIS (SEWER): 888-758-7471

WYLIE BRANCH

Topsail Township, Pender County, North Carolina

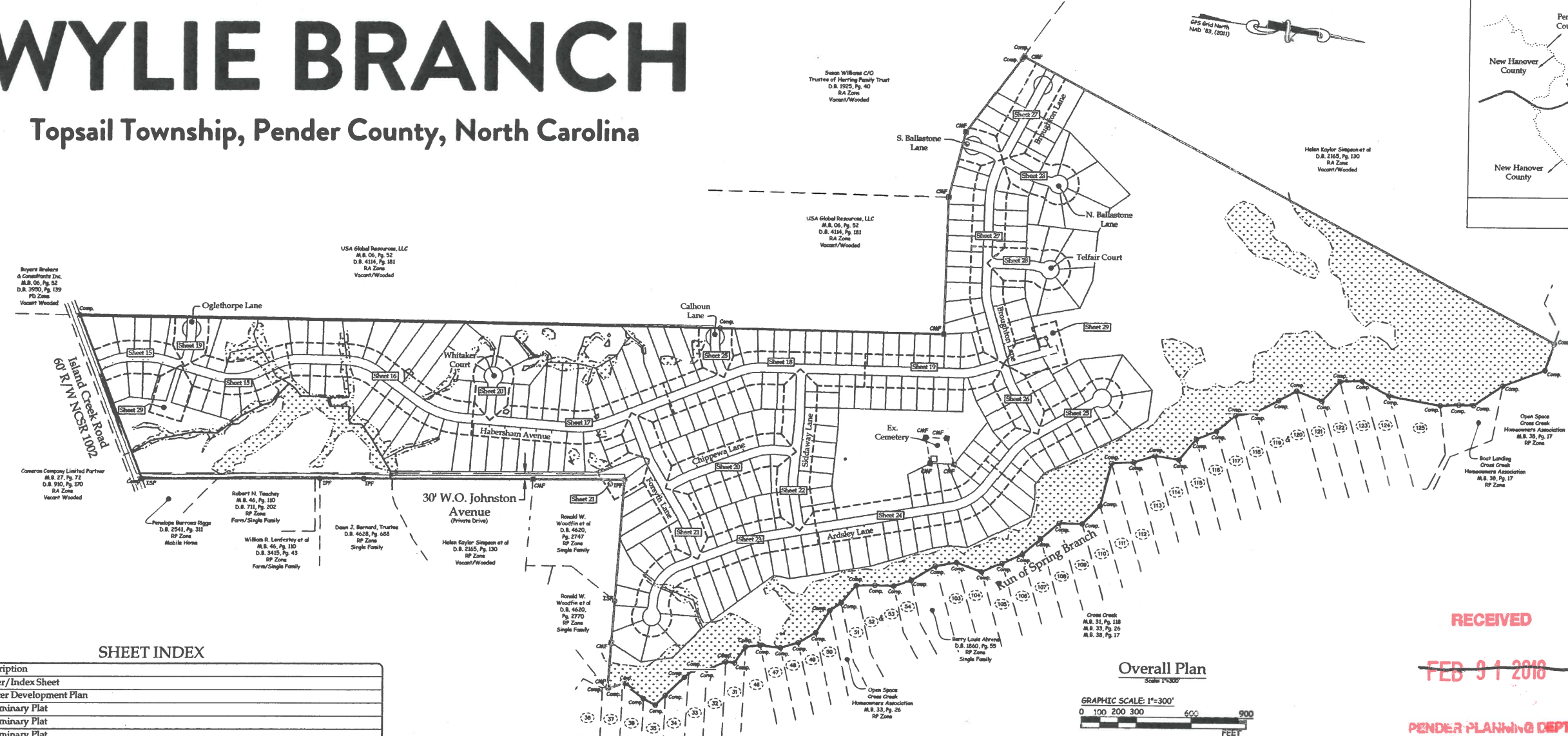
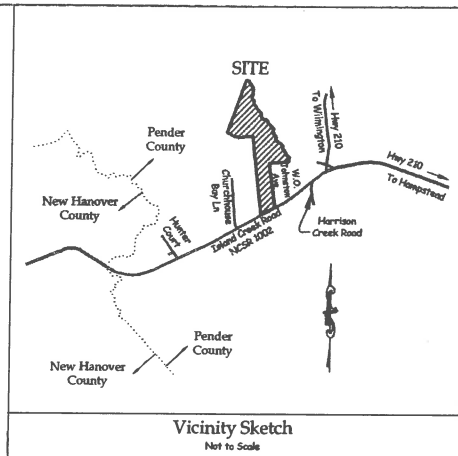

- Legend:**
- CNF - Concrete Monument Found
 - Comp - Compacted Point
 - D.B. - Deed Book
 - IPF - Iron Pipe Found
 - TSF - Iron Stake Found
 - M.B. - Map Book
 - Pg. - Page
 - R/W - Right-of-way
 - Sta. - Station
 - 125 - Existing Lot Number
 - Workline
 - - - Proposed Waterline

SHEET INDEX

Sheet	Description
1	Cover/Index Sheet
2	Master Development Plan
3	Preliminary Plat
4	Preliminary Plat
5	Preliminary Plat
6	Grading, Drainage, and Erosion & Sedimentation Control Plan
7	Grading, Drainage, and Erosion & Sedimentation Control Plan
8	Grading, Drainage, and Erosion & Sedimentation Control Plan
9	Grading, Drainage, and Erosion & Sedimentation Control Plan
10	Grading, Drainage, and Erosion & Sedimentation Control Plan
11	Grading, Drainage, and Erosion & Sedimentation Control Plan
12	Water & Sewer Plan
13	Water & Sewer Plan
14	Water & Sewer Plan
15	Plan & Profile of Habersham Avenue (Sta. 00+00 - Sta. 11+50)
16	Plan & Profile of Habersham Avenue (Sta. 11+50 - Sta. 22+00)
17	Plan & Profile of Habersham Avenue (Sta. 22+00 - Sta. 32+50)
18	Plan & Profile of Habersham Avenue (Sta. 32+50 - Sta. 44+00)
19	Plan & Profile of Habersham Avenue (Sta. 44+00 - Sta. 51+69.41) & Oglethorpe Lane
20	Plan & Profile of Whitaker Court & Chippewa Lane
21	Plan & Profile of Forsyth Lane & Offsite Sewer Force Main
22	Plan & Profile of Skidaway Lane
23	Plan & Profile of Ardsley Lane (Sta. 0+00 - Sta. 11+00)
24	Plan & Profile of Ardsley Lane (Sta. 11+00 - Sta. 22+00)
25	Plan & Profile of Ardsley Lane (Sta. 22+00 - Sta. 28+97.98) & Calhoun Lane
26	Plan & Profile of Broughton Lane (Sta. 00+00 - Sta. 11+00)
27	Plan & Profile of Broughton Lane (Sta. 11+00 - Sta. 21+21.16)
28	Plan & Profile of Telfair Court & Ballastone Lane
29	Plan & Profile of Sewer Line "A" & Sewer Line "B"
30	Sewer Detail Sheet
31	Erosion and Sedimentation Control Detail Sheet
32	Right Turn Lane Plan
33	Grading and Drainage Detail Sheet
34	Water Detail Sheet

Adjoiner Data

Lot No.	Owner(s)	D.B. / Pg.	Subdivision	M.B. / Pg.	Zone	Use(s)	Pg. No.
N/A	Pendleton Barrowe et al	D.B. 2541, Pg. 311	N/A	N/A	RP Zone	Mobile Home	3263-70-7409-0000
N/A	Robert N. Teashey et al	D.B. 731, Pg. 202	N/A	M.B. 46, Pg. 110	RP Zone	Form/Single Family	3263-61-0118-0000
N/A	William R. Lanfear et al	D.B. 4628, Pg. 43	N/A	M.B. 46, Pg. 110	RP Zone	Form/Single Family	3263-61-0118-0000
N/A	Dawn J. Bernard, Trustees	D.B. 4628, Pg. 688	N/A	N/A	RP Zone	Form/Single Family	3263-71-8334-0000
N/A	Helan Kaylor Simpson et al	D.B. 2165, Pg. 130	N/A	N/A	RP Zone	Vacant/Wooded	3263-72-8158-0000
N/A	Ronald W. Woodfin et al	D.B. 4620, Pg. 2747	N/A	N/A	RP Zone	Single Family	3263-62-1517-0000
N/A	Ronald W. Woodfin et al	D.B. 4620, Pg. 2770	N/A	N/A	RP Zone	Single Family	3263-72-8746-0000
31	Jeanette B. Conner	D.B. 3780, Pg. 112	Cross Creek	M.B. 31, Pg. 118	RP Zone	Single Family	3263-83-4638-0000
32	Jeanette B. Conner	D.B. 3780, Pg. 112	Cross Creek	M.B. 31, Pg. 118	RP Zone	Single Family	3263-83-5477-0000
33	Adam James Rodriguez	D.B. 4593, Pg. 171	Cross Creek	M.B. 31, Pg. 118	RP Zone	Single Family	3263-83-8417-0000
34	Daniel J. Altrien et al	D.B. 3025, Pg. 250	Cross Creek	M.B. 31, Pg. 118	RP Zone	Single Family	3263-83-5377-0000
35	Unknown			M.B. 31, Pg. 118	RP Zone	Vacant/Wooded	3263-83-8258-0000
36	Cross Creek Homeowners Association Inc.	D.B. 3066, Pg. 244	Cross Creek	M.B. 31, Pg. 118	RP Zone	Vacant/Wooded	3263-83-8124-0000
37	David Bishop et al	D.B. 4189, Pg. 209	Cross Creek	M.B. 31, Pg. 118	RP Zone	Single Family	3263-83-6032-0000
38	Deborah B. Taylor	D.B. 1887, Pg. 279	Cross Creek	M.B. 31, Pg. 118	RP Zone	Single Family	3263-82-6921-0000
46	Joseph J. Yabanski	D.B. 4591, Pg. 166	Cross Creek	M.B. 33, Pg. 26	RP Zone	Single Family	3263-83-3789-0000
47	JJ et al			M.B. 33, Pg. 26	RP Zone	Single Family	3263-83-3921-0000
48	James D. Crimmet et al	D.B. 4186, Pg. 291	Cross Creek	M.B. 33, Pg. 26	RP Zone	Single Family	3263-84-2091-0000
49	Parler C. Vane et al	D.B. 1973, Pg. 94	Cross Creek	M.B. 33, Pg. 26	RP Zone	Single Family	3263-84-2009-0000
50	Patrick Charles Karlsson R.	D.B. 4620, Pg. 599	Cross Creek	M.B. 33, Pg. 26	RP Zone	Single Family	3263-84-1126-0000
Open Space	Cross Creek Homeowners Association Inc.	D.B. 3066, Pg. 244	Cross Creek	M.B. 33, Pg. 26	RP Zone	Vacant/Wooded	3263-84-2228-0000
51	Thomas E. Wheeler Jr et al	D.B. 3868, Pg. 254	Cross Creek	M.B. 33, Pg. 26	RP Zone	Single Family	3263-84-0311-0000
52	Zachary Miller et al	D.B. 4607, Pg. 1443	Cross Creek	M.B. 33, Pg. 26	RP Zone	Single Family	3263-74-9423-0000
53	Zachary Miller et al	D.B. 4607, Pg. 1443	Cross Creek	M.B. 33, Pg. 26	RP Zone	Single Family	3263-74-9423-0000
54	Rose M. Giddis	D.B. 1883, Pg. 44	Cross Creek	M.B. 33, Pg. 26	RP Zone	Single Family	3263-74-8569-0000
N/A	Berry Louis Ahrens et al	D.B. 1860, Pg. 59	N/A	N/A	RP Zone	Single Family	3263-74-8711-0000
503	Tripp LLC	D.B. 4623, Pg. 68	Cross Creek	M.B. 38, Pg. 17	RP Zone	Vacant/Wooded	3263-74-7861-0000
104	Tripp LLC	D.B. 4615, Pg. 1984	Cross Creek	M.B. 38, Pg. 17	RP Zone	Vacant/Wooded	3263-74-7813-0000
105	Cross Creek Homeowners Association Inc.	D.B. 3066, Pg. 244	Cross Creek	M.B. 38, Pg. 17	RP Zone	Fund	3263-75-7008-0000
106	Zahn Ernest Crutch et al	D.B. 3132, Pg. 252	Cross Creek	M.B. 38, Pg. 17	RP Zone	Single Family	3263-75-6115-0000
107	Lorenna Mosler et al	D.B. 3048, Pg. 165	Cross Creek	M.B. 38, Pg. 17	RP Zone	Vacant/Wooded	3263-75-5256-0000
108	Cross Creek Homeowners Association Inc.	D.B. 3066, Pg. 244	Cross Creek	M.B. 38, Pg. 17	RP Zone	Fund	3263-75-4389-0000
109	Chris M. Bonnell et al	D.B. 2968, Pg. 244	Cross Creek	M.B. 38, Pg. 17	RP Zone	Single Family	3263-75-4423-0000
110	Overseas Living Trust	D.B. 4625, Pg. 877	Cross Creek	M.B. 38, Pg. 17	RP Zone	Single Family	3263-75-3834-0000

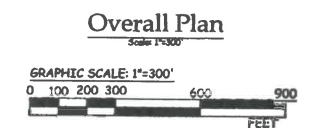

RECEIVED
 FEB 9 1 2018
 PENDER PLANNING DEPT.

RECEIVED
 FEB 16 2018
 PENDER PLANNING DEPT.

Copies Reduced

Owner/Developer:
Island Creek Developers, LLC
 100 Carolina Plantations Boulevard
 Jacksonville, North Carolina 28546



PARKER & ASSOCIATES, INC.
 Consulting Engineers - Land Surveyors - Land Planners
 Jacksonville, North Carolina
 P.O. Box 976 - 28541-0976 306 New Bridge Street - 28540
 Phone (910) 455-2414 - Fax (910) 455-3441
 Firm License Number: F-0108



Rev. 02/16/18 BLD/10/W - Revise layout for owner
 Rev. 10/11/17 BLD - Revise Workline, Add Additional Lots
 Rev. 08/08/17 BLD - Revise Per Septic Design
 Rev. 07/06/17 BLD - Revise Per Final Design

Field Book: Wylie Branch, Pg. 1-12
 Disk Name: Amd R2661
 Filename: WB-Grounding BLD
 Job No.: 516100-6392

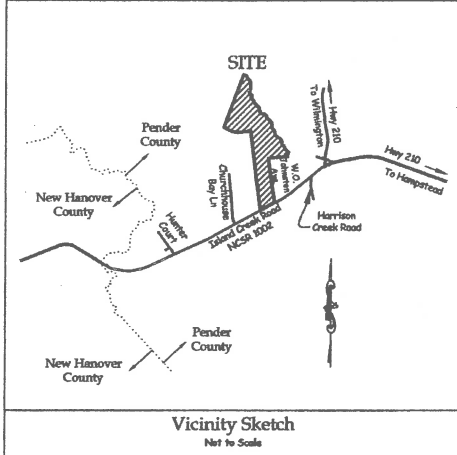

Tract Data:

Total Area	231.27 Ac.
Wetlands	44.48
Acres in Parks or other land usage	74.77 Ac.
Open Space Required	7.14 Ac.
Passive	< 3.57 Ac.
Active	> 3.57 Ac.
Percentage of Open Space	32%
Open Space Provided	74.77 Ac.
Passive	62.25 Ac.
Active	12.52 Ac.
Recreational Units	2.5 Units / \$25,000 in Lien of
Number of Lots	238
Minimum Lot Width	60'
Minimum Lot Size	12,000 SF (Public Water & Sewer Available)
Average Lot Size	20,918 SF
Minimum Building Height	35'
Linear Foot of Streets	14,342 LF
Proposed Use	Single Family Dwelling-Detached Conventional
Existing Land Use	Undeveloped
Water Service	Pender County Water
Sewer Service	Florida Sewer
Zone	RP Zone
Fire District	Hampstead Fire
Stormwater Management	Low Density
Set Density	0.92 Units/Ac.
FIN - 3263-73-0614-0000	
Docd Ref.: D.B. 4634, Pg. 1563	

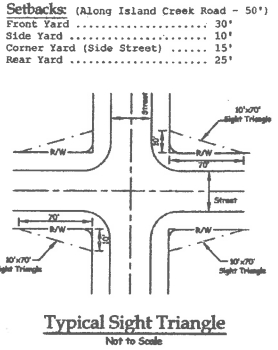

Development Phasing

Phase I

Area	42.31 Ac.
Number of Lots	58 Lots
Acres in Street R/W	4.02 Ac.
Density	0.71 Units/Ac.

Phase II

Area	99.92 Ac.
Number of Lots	51 Lots
Acres in Street R/W	3.84 Ac.
Density	1.92 Units/Ac.

Phase III

Area	28.81 Ac.
Number of Lots	54 Lots
Acres in Street R/W	3.92 Ac.
Density	0.55 Units/Ac.

Phase IV

Area	22.82 Ac.
Number of Lots	39 Lots
Acres in Street R/W	2.92 Ac.
Density	0.55 Units/Ac.

Phase V

Area	2.42 Ac.
Number of Lots	37 Lots
Acres in Street R/W	2.31 Ac.
Density	0.72 Units/Ac.

Common Areas

Common Area #2 - Passive

Area	3.06 Ac.
Acres in Wetlands	0.62 Ac.
Use	To Be Determined

Common Area #3 - Active

Area	8.04 Ac.
Acres in Wetlands	0.02 Ac.
Use	Clubhouse & Amenities

Common Area #4 - Passive

Area	59.19 Ac.
Acres in Wetlands	36.32 Ac.
Use	To Be Determined

Common Area #5 - Active

Area	1.45 Ac.
Acres in Wetlands	0.02 Ac.
Use	Emergency Access

Common Area #6 - Active

Area	2.48 Ac.
Acres in Wetlands	0.31 Ac.
Use	To Be Determined

Reserved By Owner Area

Area	10.07 Ac.
Acres in Wetlands	2.92 Ac.
Use	To Be Determined

Estimated Trip Generation

Estimated Average Daily Trips	2,266
Estimated AM Peak Hour Trips	178
Estimated PM Peak Hour Trips	238

Note: The Estimated Average Daily Trips Were Calculated According To The Institute of Transportation Engineers Trip Generation Manual 9th Edition

Legend:

- Ac. - Acreage
- CMF - Concrete Manifold Found
- Comp. - Conveyed Point
- D.B. - Dead Book
- epb - Existing phone Box
- ep - Existing Power Pole
- ex - Existing
- HOA - Home Owners Association
- IPF - Iron Pipe Found
- ZSF - Iron Stake Found
- Pg. - Page
- M.B. - Map Book
- M.B.L. - Minimum Building Line
- Min. - Minimum
- NCSR - North Carolina Secondary Road
- R - Road
- R/W - Right-of-Way
- s.t. - 25'x25' Sight Triangle
- Typ. - Typical
- 54 - Adjoiner Lot Number
- 121 - Lot Number
- Wetlands
- Overhead Power Lines
- Wetlands Line

Notes:

Cross hatched areas shown are to be used temporarily as the Cul-de-sac R/W. Upon extension of Oglethorpe Lane only the normal 50' R/W will be dedicated and the ownership of the cross hatched areas will revert to the owners of the tract in which they lie.

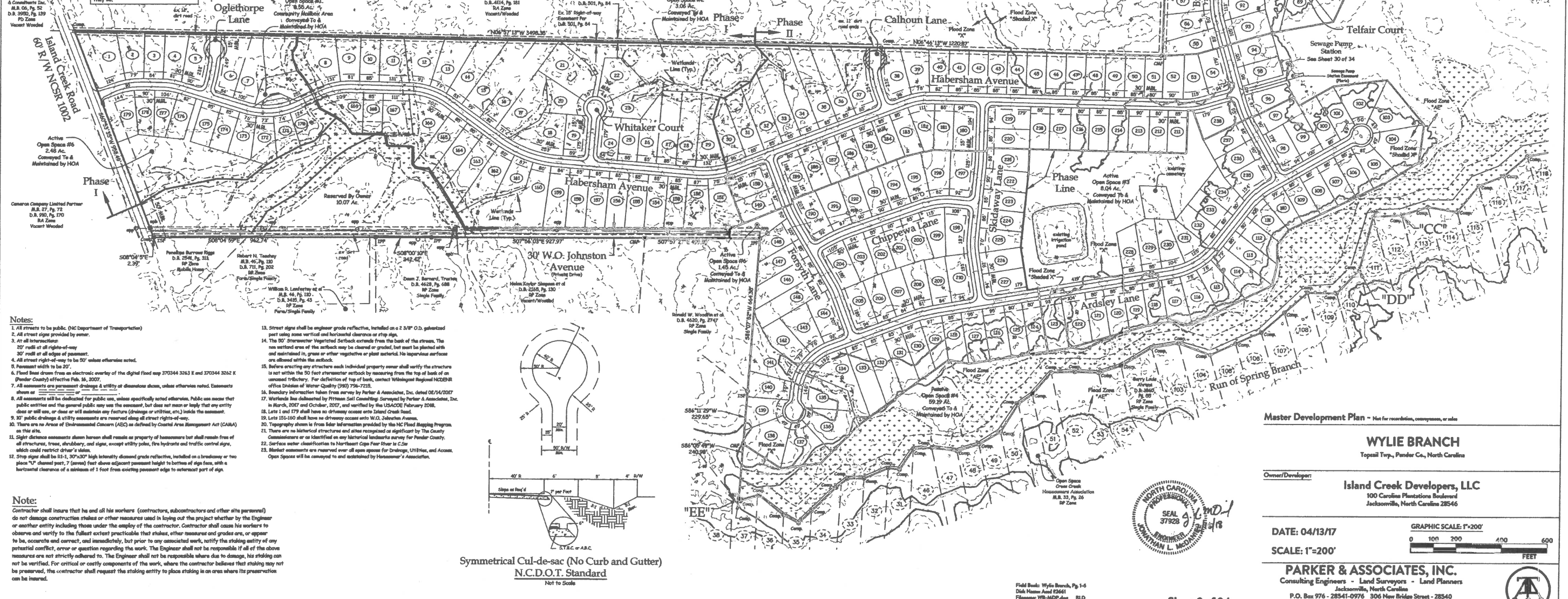
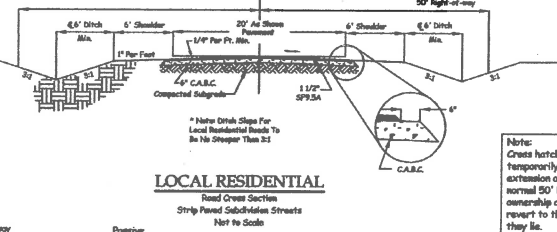
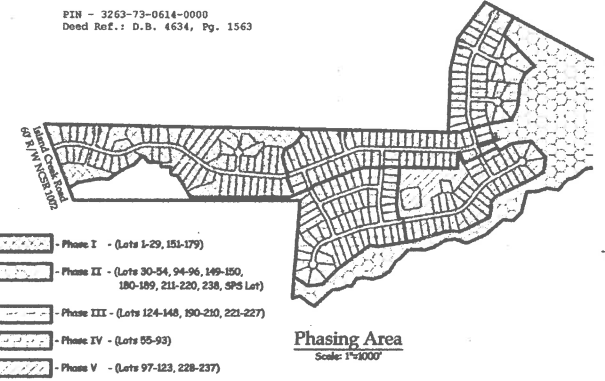

- Notes:**
- All streets to be public (NC Department of Transportation)
 - All street signs provided by owner.
 - All intersections: 30' radii at all rights-of-way 30' radii at all edges of pavement.
 - All street right-of-way to be 50' unless otherwise noted.
 - Pavement width to be 20'.
 - Flood beam drain from an electronic overlay of the digital flood map 370344 3263 E and 370344 3262 K (Pender County) effective Feb. 16, 2007.
 - All easements are permanent drainage & utility easements, unless otherwise noted. Easements shown as follows:
 - All easements will be dedicated for public use, unless specifically noted otherwise. Public use means that public utilities and the general public may use the easement, but does not mean or imply that any entry door or well use, or that it will maintain any factors (drainage or utility, etc.) inside the easement.
 - 30' public drainage & utility easements are reserved along all street rights-of-way.
 - There are no Areas of Environmental Concern (AEC) as defined by Coastal Area Management Act (CAMA) on this site.
 - Slight distance easements shown herein shall remain as property of homeowners but shall remain free of all structures, trees, shrubbery, and signs, except utility poles, fire hydrants and traffic control signs, which could restrict driver's vision.
 - Stop sign shall be 24" x 30" high high intensity diamond grade reflective, installed on a breakdown or two phase "V" channel post, 7 (seven) feet above adjacent pavement height to bottom of sign face, with a horizontal clearance of a minimum of 1 foot from existing pavement edge to outermost part of sign.

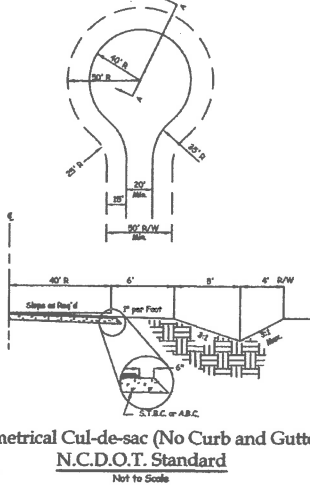

Note:

Contractor shall insure that he and all his workers (contractors, subcontractors and other site personnel) do not damage construction stakes or other measures used in laying out the project whether by the Engineer or another entity including those under the employ of the contractor. Contractor shall cause his workers to observe and verify to the fullest extent practicable that stakes, other measures and grades are, or appear to be, accurate and correct, and immediately, but prior to any associated work, notify the staking entity of any potential conflict, error or question regarding the work. The Engineer shall not be responsible if all of the above measures are not strictly adhered to. The Engineer shall not be responsible where due to damage, his staking can not be verified. For critical or costly components of the work, where the contractor believes that staking may not be preserved, the contractor shall request the staking entity to place staking in an area where its preservation can be insured.

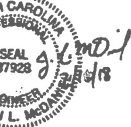

Master Development Plan - Not for construction, conveyance, or sale

WYLIE BRANCH
 Topical Trp., Pender Co., North Carolina

Owner/Developer:
Island Creek Developers, LLC
 100 Carolina Plantations Boulevard
 Jacksonville, North Carolina 28546

DATE: 04/13/17
 SCALE: 1"=200'

GRAPHIC SCALE: 1"=200'
 0 100 200 400 600 FEET

PARKER & ASSOCIATES, INC.
 Consulting Engineers - Land Surveyors - Land Planners
 Jacksonville, North Carolina
 P.O. Box 976 - 28541-0976 306 New Bridge Street - 28540
 Phone (910) 455-2414 - Fax (910) 455-3441
 Firm License Number: F-0108

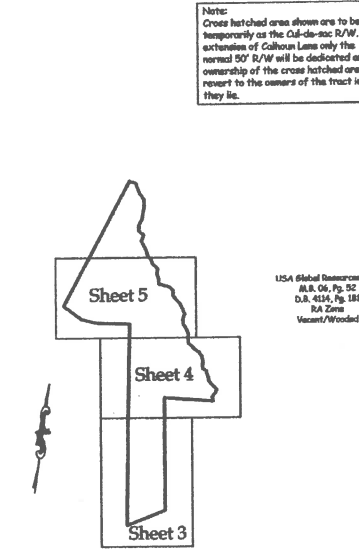
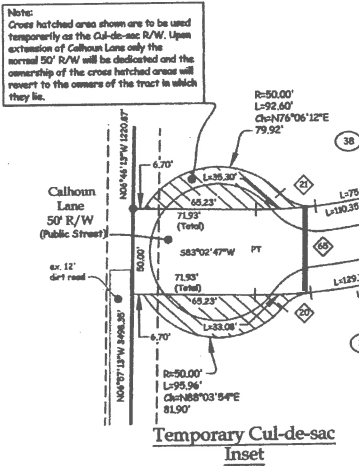
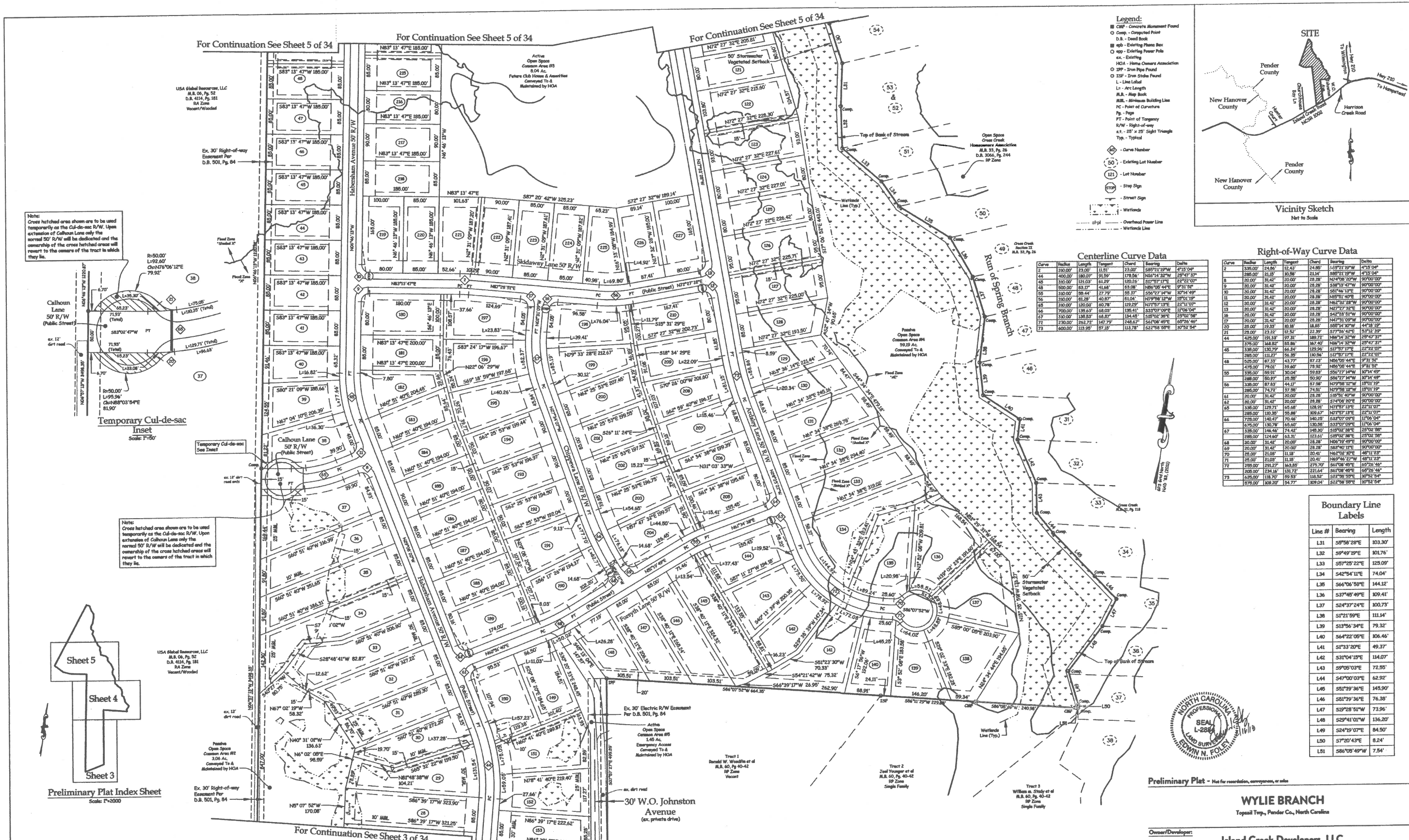

Note:
Contractor shall insure that he and all his workers (contractors, subcontractors and other site personnel) do not damage construction stakes or other measures used in laying out the project whether by the Engineer or another entity including those under the employ of the contractor. Contractor shall cause his workers to observe and verify to the fullest extent practicable that stakes, other measures and grades are, or appear to be, accurate and correct, and immediately, but prior to any associated work, notify the staking entity of any potential conflict, error or question regarding the work. The Engineer shall not be responsible if all of the above measures are not strictly adhered to. The Engineer shall not be responsible where due to damage, his staking can not be verified. For critical or costly components of the work, where the contractor believes that staking may not be preserved, the contractor shall request the staking entity to place staking in an area where its preservation can be insured.

Rev. 02/16/18 BLD/PTW - Review layout for sewer
Rev. 10/11/17 BLD - Review Wetlands, Add Additional Lots, and Review Lot Numbers
Rev. 08/16/17 BLD - Review Layout and Notes
Rev. 07/10/17 BLD - Review Comments
Rev. 07/06/17 K/W - Review per final design

- Legend:**
- CMF - Concrete Monument Found
 - Comp. - Computed Point
 - D.B. - Dead Book
 - spt - Existing Plane Box
 - spt - Existing Power Pole
 - ex - Existing
 - HOA - Home Owners Association
 - JPP - Iron Pipe Found
 - SSP - Stone Slab Found
 - L - Line Label
 - L - Arc Length
 - M.B. - Map Book
 - M.B. - Minimum Building Line
 - PC - Point of Curvature
 - PC - Page
 - PT - Point of Tangency
 - R/W - Right-of-way
 - ex - 20' x 20' Sight Triangle
 - Typ - Typical
 - - Curve Number
 - - Existing Lot Number
 - - Lot Number
 - - Strip Sign
 - - Street Sign
 - - Wetlands
 - - Wetlands Line
 - - Wetlands Line

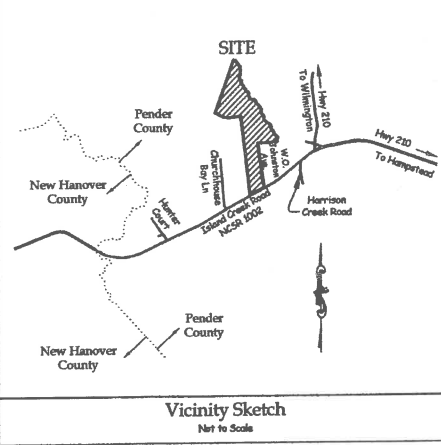

Centerline Curve Data

Curve	Radius	Length	Chord	Bearing	Delta
1	330.00	133.00	111.51	23.00°	47.50°
2	330.00	133.00	111.51	23.00°	47.50°
3	330.00	133.00	111.51	23.00°	47.50°
4	330.00	133.00	111.51	23.00°	47.50°
5	330.00	133.00	111.51	23.00°	47.50°
6	330.00	133.00	111.51	23.00°	47.50°
7	330.00	133.00	111.51	23.00°	47.50°
8	330.00	133.00	111.51	23.00°	47.50°
9	330.00	133.00	111.51	23.00°	47.50°
10	330.00	133.00	111.51	23.00°	47.50°
11	330.00	133.00	111.51	23.00°	47.50°
12	330.00	133.00	111.51	23.00°	47.50°
13	330.00	133.00	111.51	23.00°	47.50°
14	330.00	133.00	111.51	23.00°	47.50°
15	330.00	133.00	111.51	23.00°	47.50°
16	330.00	133.00	111.51	23.00°	47.50°
17	330.00	133.00	111.51	23.00°	47.50°
18	330.00	133.00	111.51	23.00°	47.50°
19	330.00	133.00	111.51	23.00°	47.50°
20	330.00	133.00	111.51	23.00°	47.50°
21	330.00	133.00	111.51	23.00°	47.50°
22	330.00	133.00	111.51	23.00°	47.50°
23	330.00	133.00	111.51	23.00°	47.50°

Right-of-Way Data

Curve	Radius	Length	Chord	Bearing	Delta
1	330.00	133.00	111.51	23.00°	47.50°
2	330.00	133.00	111.51	23.00°	47.50°
3	330.00	133.00	111.51	23.00°	47.50°
4	330.00	133.00	111.51	23.00°	47.50°
5	330.00	133.00	111.51	23.00°	47.50°
6	330.00	133.00	111.51	23.00°	47.50°
7	330.00	133.00	111.51	23.00°	47.50°
8	330.00	133.00	111.51	23.00°	47.50°
9	330.00	133.00	111.51	23.00°	47.50°
10	330.00	133.00	111.51	23.00°	47.50°
11	330.00	133.00	111.51	23.00°	47.50°
12	330.00	133.00	111.51	23.00°	47.50°
13	330.00	133.00	111.51	23.00°	47.50°
14	330.00	133.00	111.51	23.00°	47.50°
15	330.00	133.00	111.51	23.00°	47.50°
16	330.00	133.00	111.51	23.00°	47.50°
17	330.00	133.00	111.51	23.00°	47.50°
18	330.00	133.00	111.51	23.00°	47.50°
19	330.00	133.00	111.51	23.00°	47.50°
20	330.00	133.00	111.51	23.00°	47.50°
21	330.00	133.00	111.51	23.00°	47.50°
22	330.00	133.00	111.51	23.00°	47.50°
23	330.00	133.00	111.51	23.00°	47.50°

Boundary Line Labels

Line #	Bearing	Length
L31	S5°58'28"E	103.30'
L32	S9°49'19"E	101.76'
L33	S5°23'22"E	125.09'
L34	S42°54'11"E	74.04'
L35	S64°06'58"E	144.12'
L36	S37°48'49"E	109.41'
L37	S24°37'24"E	100.73'
L38	S1°21'59"E	111.14'
L39	S13°56'34"E	79.32'
L40	S64°22'08"E	106.46'
L41	S1°33'20"E	49.37'
L42	S31°04'15"E	114.07'
L43	S9°05'03"E	72.95'
L44	S47°00'03"E	62.92'
L45	S51°39'36"E	145.90'
L46	S51°39'36"E	76.38'
L47	S12°28'51"W	73.96'
L48	S29°41'01"W	136.20'
L49	S24°19'07"E	84.50'
L50	S7°20'43"E	8.24'
L51	S8°08'49"W	7.54'



WYLIE BRANCH
Topical Trp., Pender Co., North Carolina

Island Creek Developers, LLC
100 Carolina Plantations Boulevard
Jacksonville, North Carolina 28546

DATE: 06/16/17
SCALE: 1"=100'

GRAPHIC SCALE: 1"=100'
0 50 100 200 300 FEET

PARKER & ASSOCIATES, INC.
Consulting Engineers - Land Surveyors - Land Planners
Jacksonville, North Carolina
P.O. Box 976 - 28541-0976 305 New Bridge Street - 28540
Phone (910) 455-2414 - Fax (910) 455-3441
Firm License Number: F-0108

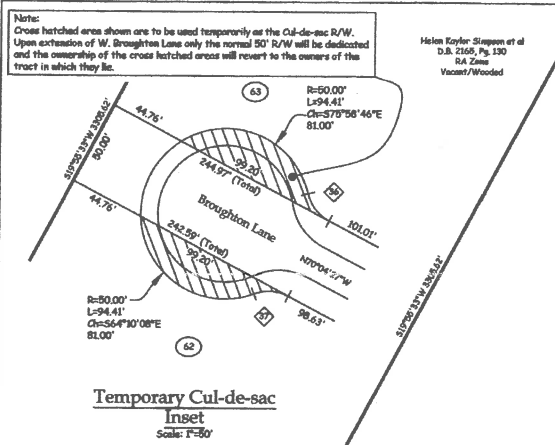

Temporary Cul-de-sac Inset Scale: F=50'

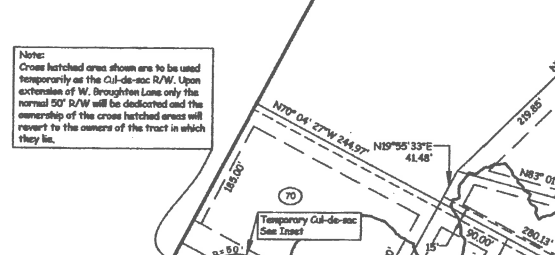

Temporary Cul-de-sac Inset Scale: F=50'

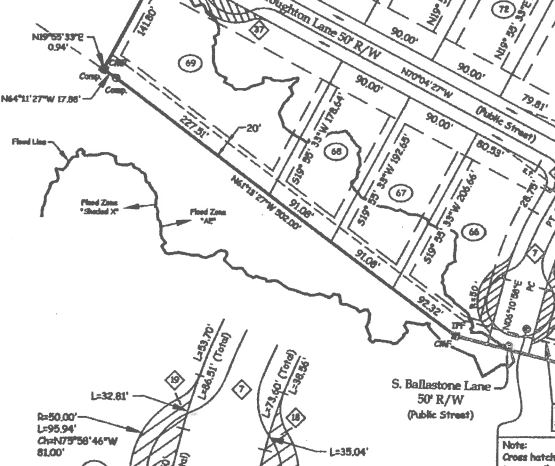

Temporary Cul-de-sac Inset Scale: F=50'



Temporary Cul-de-sac Inset Scale: F=50'

Note: Contractor shall ensure that he and all his workers (contractors, subcontractors and other site personnel) do not damage construction shales or other measures used in laying out the project whether by the Engineer or another entity including those under the employ of the contractor. Contractor shall cause his workers to observe and verify to the fullest extent practicable that stakes, other markers and grades are, or appear to be, accurate and correct, and immediately, but prior to any associated work, notify the staking entity of any potential conflict, error or question regarding the work. The Engineer shall not be responsible if all of the above measures are not strictly adhered to. The Engineer shall not be responsible where due to damage, his staking can not be verified. For critical or costly components of the work, where the contractor believes that staking may not be preserved, the contractor shall request the staking entity to place staking in an area where its preservation can be insured.

Boundary Line "AA" To "BB"			Boundary Line "AA" To "BB"			Boundary Line "BB" To "CC"			Boundary Line "BB" To "CC"			Boundary Line "BB" To "CC"			Boundary Line "BB" To "CC"			
Line #	Bearing	Length	Line #	Bearing	Length	Line #	Bearing	Length	Line #	Bearing	Length	Line #	Bearing	Length	Line #	Bearing	Length	
L1	S79°54'39"E	188.08'	L11	S36°23'52"E	130.37'	L21	S65°53'07"E	138.50'	L31	S6°56'28"E	303.30'	L41	S1°33'20"E	49.37'	L51	S86°00'49"W	7.54'	
L2	S28°23'14"E	246.19'	L12	S30°39'23"E	139.59'	L22	S7°00'26"E	125.32'	L32	S9°49'19"E	101.76'	L42	S31°04'10"E	114.07'				
L3	S42°11'40"E	191.80'	L13	S18°26'09"E	116.51'	L23	S48°05'51"E	132.52'	L33	S67°32'22"E	123.09'	L43	S9°08'03"E	72.58'				
L4	S61°13'49"E	180.43'	L14	S45°24'19"E	130.93'	L24	S48°46'43"E	132.31'	L34	S42°54'11"E	74.04'	L44	S47°00'03"E	62.92'				
L5	S107°34'03"E	100.93'	L15	S29°23'43"E	120.02'	L25	S32°06'18"E	121.21'	L35	S66°06'58"E	148.50'	L45	S81°39'36"E	76.38'				
L6	S2°18'46"W	283.55'	L16	S98°46'29"E	146.86'	L26	S32°18'10"E	121.39'	L36	S37°45'49"E	109.41'	L46	S81°39'36"E	76.38'				
L7	S20°47'22"W	167.68'	L17	S1°13'41"W	132.65'	L27	S11°48'07"W	147.83'	L37	S24°37'24"E	100.73'	L47	S10°28'53"W	73.96'				
L8	S107°01'51"E	121.80'	L18	S28°01'39"E	120.06'	L28	S17°36'02"E	118.95'	L38	S1°21'59"E	111.14'	L48	S29°41'01"W	136.20'				
L9	S56°04'28"E	146.72'	L19	S10°25'48"E	123.17'	L29	S39°12'24"E	153.01'	L39	S13°56'34"E	79.32'	L49	S24°19'07"E	84.50'				
L10	S13°41'24"W	151.00'	L20	S54°05'25"E	241.54'	L30	S29°44'30"E	100.42'	L40	S64°22'09"E	106.46'	L50	S7°20'43"E	8.24'				

Rev. 02/16/15 BLD/SHW - Revis layout for error
 Rev. 10/17/17 BLD - Add Curve Data, Station Lists 25 and 85, Revis Lot Numbers
 Rev. 08/16/17 BLD - Revis Layout and Notes
 Rev. 07/10/17 BLD - Revis Easements
 Rev. 07/06/17 SHW - Revis per final design

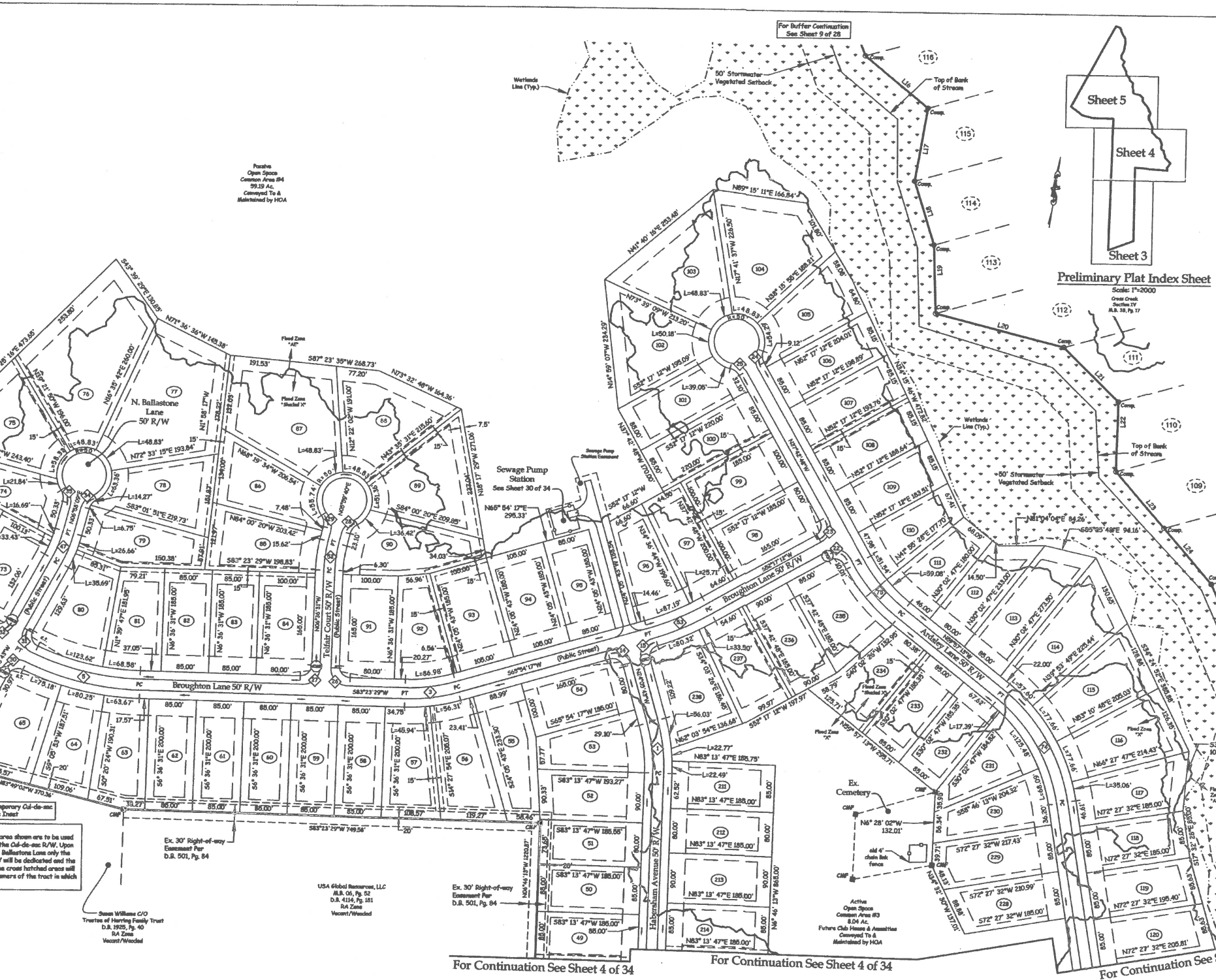

For Continuation See Sheet 4 of 34

Right-of-Way Curve Data						Right-of-Way Curve Data							
Curve	Radius	Length	Tangent	Chord	Bearing	Curve	Radius	Length	Tangent	Chord	Bearing		
1	125.00'	185.57'	51.00'	125.00'	N82°25'58"W	17°19'30"	36	25.00'	21.03'	11.88'	30.41'	N87°07'32"W	48°11'23"
2	280.00'	86.30'	43.42'	280.00'	N82°25'58"W	17°19'30"	37	25.00'	21.03'	11.88'	30.41'	S45°58'46"E	48°11'23"
3	330.00'	102.18'	51.62'	330.00'	N24°38'53"E	17°29'12"	47	250.00'	62.39'	31.33'	20.41'	S85°49'32"W	48°11'23"
4	295.00'	86.30'	43.42'	295.00'	N24°38'53"E	17°29'12"	48	250.00'	62.39'	31.33'	20.41'	N15°58'26"E	14°00'34"
5	295.00'	86.30'	43.42'	295.00'	S83°20'22"E	28°33'00"	52	295.00'	62.39'	31.33'	20.41'	N00°18'20"W	12°36'11"
6	295.00'	86.30'	43.42'	295.00'	S83°20'22"E	28°33'00"	53	295.00'	62.39'	31.33'	20.41'	N89°05'44"E	12°36'11"
7	330.00'	102.18'	51.62'	330.00'	S13°34'30"W	14°47'44"	58	510.00'	124.78'	62.09'	124.49'	N89°05'44"E	12°36'11"
8	280.00'	86.30'	43.42'	280.00'	S13°34'30"W	14°47'44"	62	478.00'	112.50'	56.72'	112.43'	N89°05'44"E	12°36'11"
9	280.00'	86.30'	43.42'	280.00'	S13°34'30"W	14°47'44"	63	280.00'	62.39'	31.33'	20.41'	N89°05'44"E	12°36'11"
10	280.00'	86.30'	43.42'	280.00'	S13°34'30"W	14°47'44"	64	280.00'	62.39'	31.33'	20.41'	N89°05'44"E	12°36'11"
11	280.00'	86.30'	43.42'	280.00'	S13°34'30"W	14°47'44"	65	280.00'	62.39'	31.33'	20.41'	N89°05'44"E	12°36'11"
12	280.00'	86.30'	43.42'	280.00'	S13°34'30"W	14°47'44"	66	280.00'	62.39'	31.33'	20.41'	N89°05'44"E	12°36'11"
13	280.00'	86.30'	43.42'	280.00'	S13°34'30"W	14°47'44"	67	280.00'	62.39'	31.33'	20.41'	N89°05'44"E	12°36'11"
14	280.00'	86.30'	43.42'	280.00'	S13°34'30"W	14°47'44"	68	280.00'	62.39'	31.33'	20.41'	N89°05'44"E	12°36'11"
15	280.00'	86.30'	43.42'	280.00'	S13°34'30"W	14°47'44"	69	280.00'	62.39'	31.33'	20.41'	N89°05'44"E	12°36'11"
16	280.00'	86.30'	43.42'	280.00'	S13°34'30"W	14°47'44"	70	280.00'	62.39'	31.33'	20.41'	N89°05'44"E	12°36'11"
17	280.00'	86.30'	43.42'	280.00'	S13°34'30"W	14°47'44"	71	280.00'	62.39'	31.33'	20.41'	N89°05'44"E	12°36'11"
18	280.00'	86.30'	43.42'	280.00'	S13°34'30"W	14°47'44"	72	280.00'	62.39'	31.33'	20.41'	N89°05'44"E	12°36'11"
19	280.00'	86.30'	43.42'	280.00'	S13°34'30"W	14°47'44"	73	280.00'	62.39'	31.33'	20.41'	N89°05'44"E	12°36'11"
20	280.00'	86.30'	43.42'	280.00'	S13°34'30"W	14°47'44"	74	280.00'	62.39'	31.33'	20.41'	N89°05'44"E	12°36'11"
21	280.00'	86.30'	43.42'	280.00'	S13°34'30"W	14°47'44"	75	280.00'	62.39'	31.33'	20.41'	N89°05'44"E	12°36'11"
22	280.00'	86.30'	43.42'	280.00'	S13°34'30"W	14°47'44"	76	280.00'	62.39'	31.33'	20.41'	N89°05'44"E	12°36'11"
23	280.00'	86.30'	43.42'	280.00'	S13°34'30"W	14°47'44"	77	280.00'	62.39'	31.33'	20.41'	N89°05'44"E	12°36'11"
24	280.00'	86.30'	43.42'	280.00'	S13°34'30"W	14°47'44"	78	280.00'	62.39'	31.33'	20.41'	N89°05'44"E	12°36'11"
25	280.00'	86.30'	43.42'	280.00'	S13°34'30"W	14°47'44"	79	280.00'	62.39'	31.33'	20.41'	N89°05'44"E	12°36'11"
26	280.00'	86.30'	43.42'	280.00'	S13°34'30"W	14°47'44"	80	280.00'	62.39'	31.33'	20.41'	N89°05'44"E	12°36'11"
27	280.00'	86.30'	43.42'	280.00'	S13°34'30"W	14°47'44"	81	280.00'	62.39'	31.33'	20.41'	N89°05'44"E	12°36'11"
28	280.00'	86.30'	43.42'	280.00'	S13°34'30"W	14°47'44"	82	280.00'	62.39'	31.33'	20.41'	N89°05'44"E	12°36'11"
29	280.00'	86.30'	43.42'	280.00'	S13°34'30"W	14°47'44"	83	280.00'	62.39'	31.33'	20.41'	N89°05'44"E	12°36'11"
30	280.00'	86.30'	43.42'	280.00'	S13°34'30"W	14°47'44"	84	280.00'	62.39'	31.33'	20.41'	N89°05'44"E	12°36'11"
31	280.00'	86.30'	43.42'	280.00'	S13°34'30"W	14°47'44"	85	280.00'	62.39'	31.33'	20.41'	N89°05'44"E	12°36'11"
32	280.00'	86.30'	43.42'	280.00'	S13°34'30"W	14°47'44"	86	280.00'	62.39'	31.33'	20.41'	N89°05'44"E	12°36'11"
33	280.00'	86.30'	43.42'	280.00'	S13°34'30"W	14°47'44"	87	280.00'	62.39'	31.33'	20.41'	N89°05'44"E	12°36'11"
34	280.00'	86.30'	43.42'	280.00'	S13°34'30"W	14°47'44"	88	280.00'	62.39'	31.33'	20.41'	N89°05'44"E	12°36'11"

Rev. 02/16/15 BLD/SHW - Revis layout for error
 Rev. 10/17/17 BLD - Add Curve Data, Station Lists 25 and 85, Revis Lot Numbers
 Rev. 08/16/17 BLD - Revis Layout and Notes
 Rev. 07/10/17 BLD - Revis Easements
 Rev. 07/06/17 SHW - Revis per final design

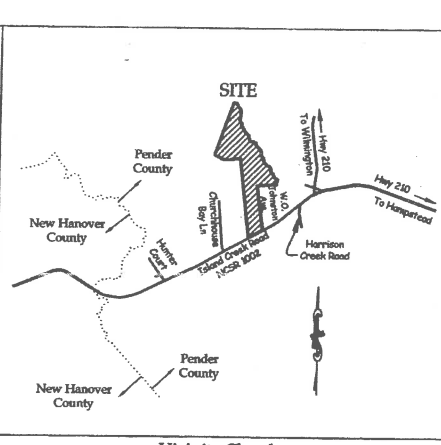

Vicinity Sketch Not to Scale

Legend:

- CMF - Concrete Monument Found
- Comp. - Computed Point
- D.B. - Dead Bank
- Exc. - Existing
- HOA - Home Owners Association
- L - Line Label
- L.B. - Left Bank
- M.B. - Midstream Building Line
- PC - Point of Curvature
- Pg. - Page
- PT - Point of Tangency
- R/W - Right-of-way
- s.t. - 25' x 25' Sight Triangle
- Typ. - Typical

(105) - Existing Lot Number
 (95) - Lot Number
 (100) - Shop Sign
 (101) - Street Sign
 (102) - Wetlands
 (103) - Overhead Power Line
 (104) - Wetlands Line

WYLLIE BRANCH
 Topical Trlp., Pender Co., North Carolina

Island Creek Developers, LLC
 100 Carolina Plantations Boulevard
 Jacksonville, North Carolina 28546

PARKER & ASSOCIATES, INC.
 Consulting Engineers - Land Surveyors - Land Planners
 Jacksonville, North Carolina
 P.O. Box 976 - 28541-0976 306 New Bridge Street - 28540
 Phone (910) 455-2414 - Fax (910) 455-3441
 Firm License Number: F-0108

DATE: 06/16/17
 SCALE: 1"=100'

GRAPHIC SCALE: 1"=100'

0 50 100 200 300 FEET

Professional Seal
 NORTH CAROLINA
 PROFESSIONAL LAND SURVEYOR
 SEAL
 L-2884
 EDWIN N. FOLEY
 11/16

Sheet 5 of 34

Note:

Contractor shall insure that he and all his workers (contractors, subcontractors and other site personnel) do not damage construction stakes or other measures used in laying out the project whether by the Engineer or another entity including those under the employ of the contractor. Contractor shall cause his workers to observe and verify to the fullest extent practicable that stakes, other measures and grades are, or appear to be, accurate and correct, and immediately, but prior to any associated work, verify the staking entry of any potential conflict, error or question regarding the work. The Engineer shall not be responsible if all of the above measures are not strictly adhered to. The Engineer shall not be responsible where due to damage, his staking can not be verified. For critical or costly components of the work, where the contractor believes that staking may not be preserved, the contractor shall request the staking entry to place staking in an area where its preservation can be insured.

Site Benchmark

CP #4
Iron Stake Set
N=230,271.79
E=2,367,676.58
Elev. 32.71

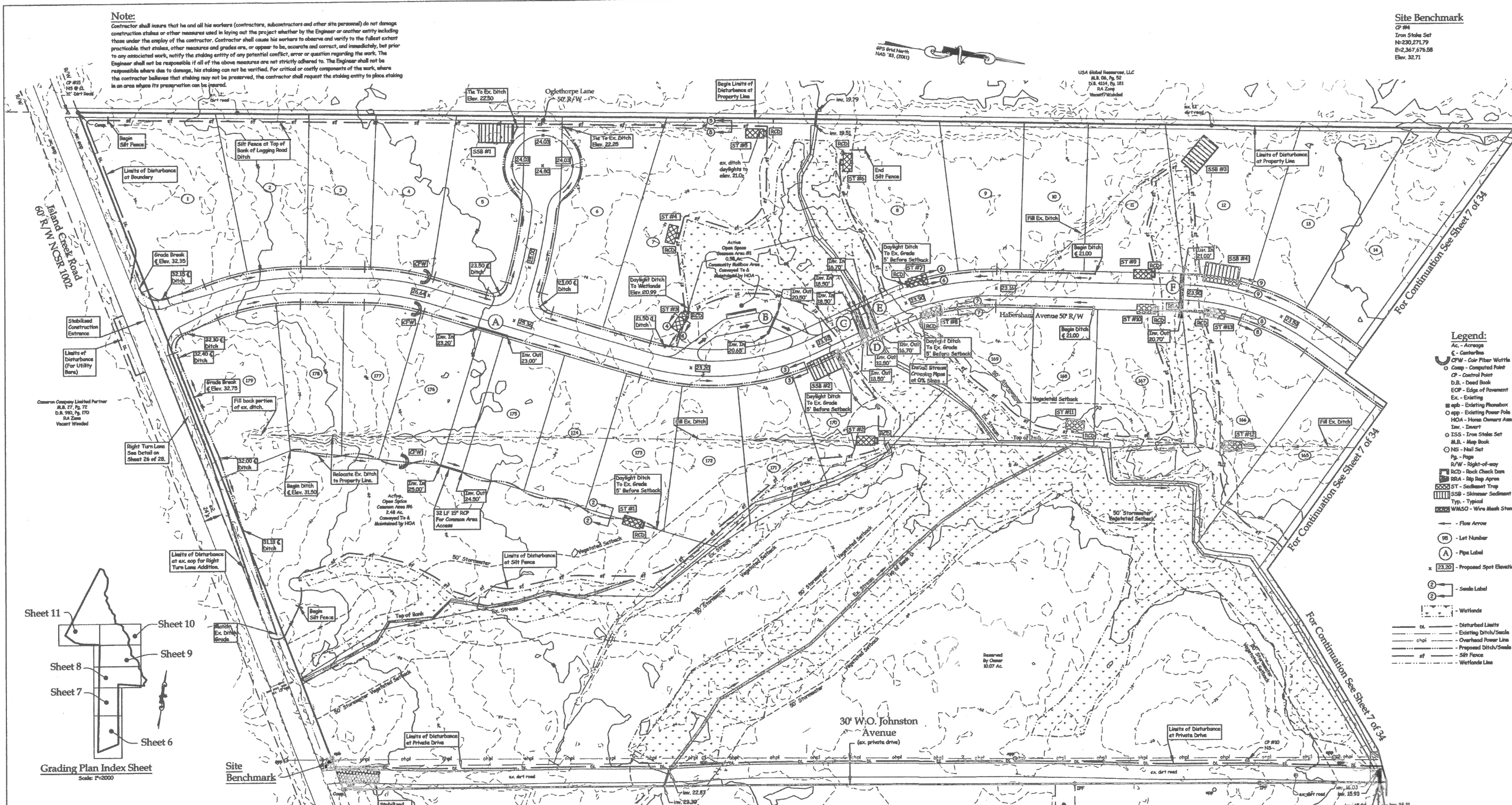

Legend:

- Ac - Acreage
 - C - Centerline
 - CFW - Coir Filter Wall/Fill
 - Comp - Compacted Point
 - CP - Control Point
 - D.B. - Dead Book
 - EOP - Edge of Pavement
 - Ex - Existing
 - Exp - Existing Pile
 - HOA - Home Owners Association
 - Inv. - Invert
 - ISS - Iron Stake Set
 - M.S. - Map Book
 - NS - Nail Set
 - Pp - Page
 - R/W - Right-of-way
 - RCD - Rock Check Dam
 - RRA - Rip Rap Apron
 - ST - Sediment Trap
 - SSB - Silt Sediment Basin
 - Typ - Typical
 - WMSO - Wire Mesh Stone Outlet
-
- - Flow Arrow
 - 98 - Lot Number
 - A - Pipe Label
 - x 23.20 - Proposed Spot Elevation
 - 2 - Sewer Label
 - 2 - Wetlands
-
- DL - Disturbed Limits
 - ED - Existing Ditch/Seals
 - OP - Overhead Power Lines
 - PP - Proposed Ditch/Seals
 - SF - Silt Fence
 - WL - Wetlands Line

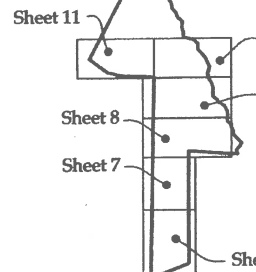

Grading Plan Index Sheet
Scale: P=2000

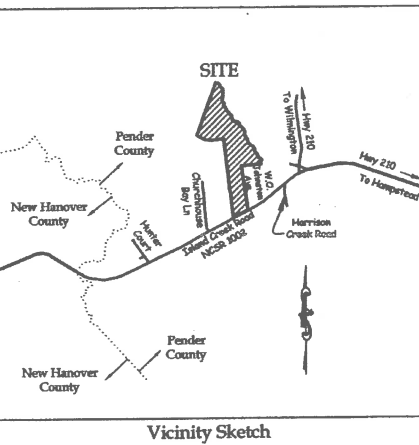

Vicinity Sketch
Not to Scale

Erosion and Sedimentation Control Notes:

1. Clearing or grading operations shall begin at low points of outfall release or other locations where sediment control measures are shown on the plan and the sediment control devices (sediment traps, silt fences, etc.) shall be installed before or simultaneously with the disturbance of any area draining to the device.
2. Sediment control devices and structures shall be installed, maintained and amended as needed to provide effective control of accelerated erosion and sedimentation until the contributing watersheds are stabilized.
3. Construction Sequence:
 - A. Notify Engineer, owner and Land Quality Section prior to beginning construction.
 - B. Install stabilized construction entrance at both points of access. W.O. Johnston is only to be used for access until the wetlands crossings are installed.
 - C. Limits of clearing will be as shown. Owner may lessen the amount to clear. Confirm prior to start of work. Silt fence shall be installed at the down slope edge of clearing immediately after a lot is cleared. Silt fences shall be maintained until the lot is stabilized completely. Silt fences are shown based on topographic information in the locations expected to be needed to trap sediment prior to entering down slope areas. Actual locations of installation shall be adjusted to the actual physical on site topography. That is, where silt

- D. Clear & grub entire area within the clearing limits as shown.
- E. Strip topsoil & stockpile for later use.
- F. Construct sediment traps and rock check dams where shown. Construct drainage swales. Install storm drainage piping.
- G. Immediately seed, mulch and install temporary liners to swales.
- H. Rough grade streets.
- I. Install water main.
- J. Maintain erosion control measures as needed to assure full functionality.
- K. Fine grade street. Place CABC over compacted subgrade. Install asphalt surface course.
- L. Complete fine grading of roadside shoulders and swales.
- M. Re-seed and mulch shoulders and swales. Install liners on all swales.
- N. Provide ground stabilization (Temporary or Permanent) on perimeter areas and slopes greater than 3:1 within 7 days following the completion of any phase of grading or construction and 14 days for all other areas internal to the project.

4. Seeding Specifications:
Apply lime and fertilizer and work into 4 - 6 inches of soil. Seed mixture shall be distributed uniformly and covered with a clean straw mulch. All mulch shall be crimped or asphalt tacked to hold in place. Material and application rates as follows, and are generally considered minimums. *Mulch rate to be doubled in ripened soil.

Material	Application Rate
Lime	3000 lbs./ac.
Fertilizer (10-10-10)	750 lbs./ac.
Mulch	2 tons/ac.
Asphalt Tack	435 gal./ac. (Max)

Common Bermuda (Unhulled Sept. 1 - April 1)	Application Rate
Hulled April 1 - Sept. 1	100 lbs./ac.
"Rebel" Fescue	75 lbs./ac.
Rye Grain (Sept. 1 - April 1 only)	50 lbs./ac.
German Millet (April 1 - Sept. 1 only)	50 lbs./ac.

Temporary Seeding	Application Rate
Dec. 1 - April 15	50 lbs./ac.
Kobe Lespedeza	120 lbs./ac.
Rye Grain	40 lbs./ac.
April 15 - Aug. 15	40 lbs./ac.
German Millet	40 lbs./ac.
Aug. 15 - Dec. 30	40 lbs./ac.
Rye Grain	120 lbs./ac.

PHASE I LAND DISTURBANCE:

Roads, Drains, and Lots 1-29 and 153-181	-35.8 Ac.
Offsite Sewer	-18.4 Ac.
Total	-54.2 Ac.

Field Book: Wylie Branch, Pg 1-12
Disk Number: Amd 23461
Plan Name: WBL-Gen-Inv BLD
Job No: 586130-4922

Grading, Drainage, Erosion and Sedimentation Control Plan

WYLIE BRANCH
Topical Trp., Pender Co., North Carolina

Owner/Developer: **Island Creek Developers, LLC**
100 Carolina Plantations Boulevard
Jacksonville, North Carolina 28546

DATE: 06/16/17
SCALE: 1"=60'

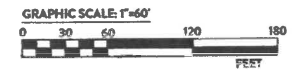

PARKER & ASSOCIATES, INC.
Consulting Engineers - Land Surveyors - Land Planners
Jacksonville, North Carolina
P.O. Box 976 - 28541-0976 306 New Bridge Street - 28540
Phone (910) 455-2414 - Fax (910) 455-3441
Firm License Number: P-0109



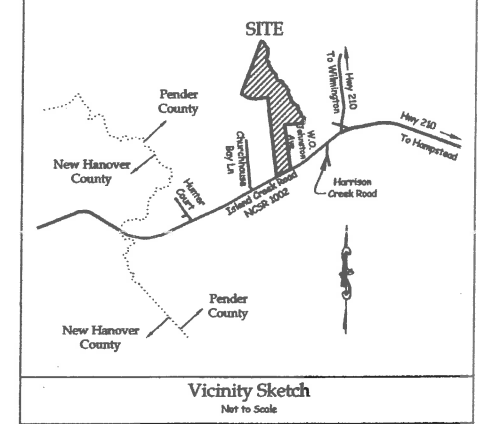
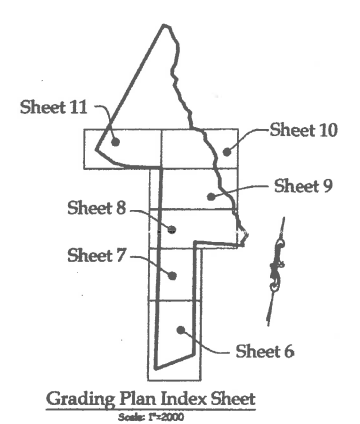
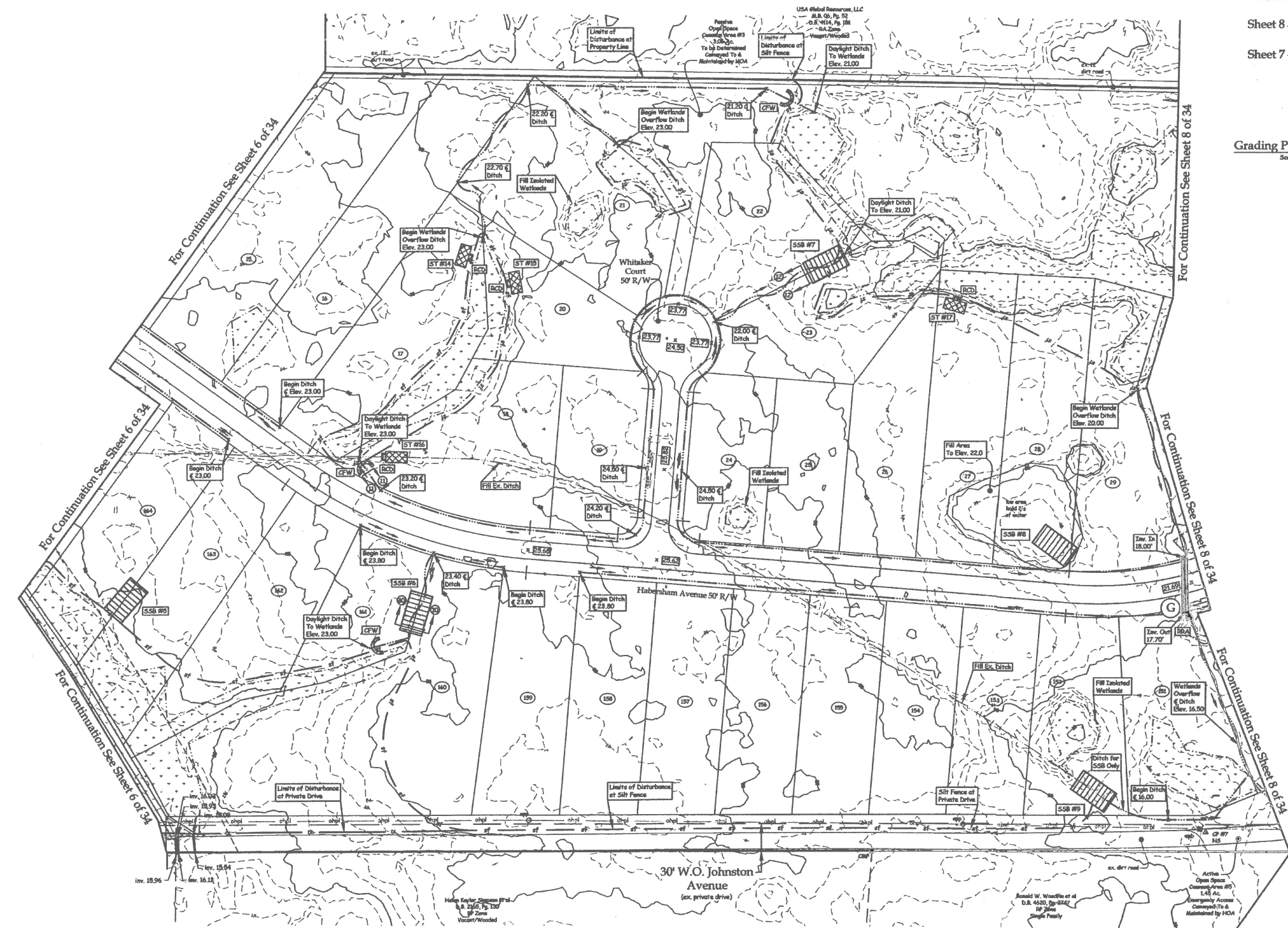

- Legend:**
- Centerline
 - CFW - Coir Fiber Wetlands
 - CMF - Concrete Monument Found
 - Comp - Computed Point
 - CP - Control Point
 - D.B. - Dated Book
 - ECF - Edge of Footprint
 - Ex - Existing
 - exp - Existing Power Pole
 - Inv - Invert
 - M.B. - Map Book
 - NS - Nail Set
 - Pg - Page
 - R/W - Right-of-way
 - RCD - Rock Check Dam
 - RSA - Rip Rap Area
 - ST - Sediment Trap
 - ST - Stormwater Sediment Basin
 - Typ - Typical
 - WMSO - Wire Mesh Stone Outlet
 - Flow Arrow
 - Lot Number
 - Pipe Label
 - Proposed Spot Elevation
 - Wetlands
 - Disturbed Limits Line
 - Existing Ditch/Swale
 - Overhead Power Line
 - Proposed Ditch/Swale
 - Silt Fence
 - Wetlands Line

- ROADS & DRAINAGE NOTES:**
- The streets to be constructed for this project are subject to the Department of Transportation Certification Program and Quality Management System Maintenance Version Requirements. The Contractor, at his expense, shall provide test results on 1) Subgrade, 2) Base and 3) Pavement. The Contractor shall insure that all construction and testing is performed in accordance with the N.C. Department of Transportation "Standard Specifications for Roads and Structures", latest edition, 2006 Hot Mix Asphalt Specifications and Manual, and "Quality Management System Maintenance Version", and shall report the testing and/or core locations, test method, results and D.O.T. allowable range or tolerance, as applicable. Subgrade shall be tested for density and shall be preapproved by the testing Engineer or the Engineer or Surveyor who will issue the Final Certification. Base and pavement shall both be tested for density and thickness. If Parker & Associates is administering the construction they must also preapprove the stone. Twenty-four (24) hour advance scheduling before approval. Testing for pavement shall be certified by either a professional Engineer or properly certified QMS technician and shall be in accordance with QMS criteria. Required thickness for this project is as shown on the plans. Note that thickness for widening or turn lanes is greater than that for internal streets.
 - Minimum Densities:
Subgrade 100%
Stone Base 100%
SF 9.5A 90%
S 9.5B 92%
I 9.5B 92%
B 9.5B 92%
 - Notify the Engineer or Surveyor, who will issue the overall Final Certification, of all phases of Roadway Construction.
 - All material used for any type of catch basin or inlet shall be produced in the USA.
 - A minimum eight (8) feet of 10'X70' shall be maintained along the right-of-way of all internal intersections.
 - 20 foot radii at right-of-way intersections, 30 foot radii at edge of pavement intersections.
 - All culverts under streets shall be reinforced concrete per North Carolina Department of Transportation Specifications, unless otherwise specified and/or approved by the Engineer and/or Department of Transportation.
 - All roads shall be public and built to NCDOT Standards.
 - There shall be no encroachments within the NCDOT Right-of-way.
 - All materials and practices shall meet North Carolina Department of Transportation Standards.
 - For other detailed construction notes, see plans and profiles.

Note:
Contractor shall insure that he and all his workers (contractors, subcontractors and other site personnel) do not damage construction stakes or other measures used in laying out the project whether by the Engineer or another entity including those under the employ of the contractor. Contractor shall cause his workers to observe and verify to the fullest extent practicable that stakes, other measures and grades are, or appear to be, accurate and correct, and immediately, but prior to any associated work, notify the staking entity of any potential conflict, error or question regarding the work. The Engineer shall not be responsible if all of the above measures are not strictly adhered to. The Engineer shall not be responsible where data to damage, his staking can not be verified. For critical or costly components of the work, where the contractor believes that staking may not be preserved, the contractor shall request the staking entity to place staking in an area where its preservation can be insured.

PHASE I LAND DISTURBANCE:

Roads, Drainage, and Lots 1-29 and 155-181	- 35.8 Ac.
Offsite Sewer	- 18.4 Ac.
Total	- 54.2 Ac.

Rev. 02/16/18 BLD/VDHW - Revised layout for sewer
Rev. 10/11/17 BLD - Revised Lot Numbers
Rev. 08/10/17 BLD - Revised Per NCDOT Erosion Control
Rev. 07/19/17 BLD - Revised For Erosion Control Submittal
Rev. 07/10/17 BLD - Revised Grading Plan Index
Rev. 07/06/17 BLD - Revised Per Final Design

Field Book: Wylie Branch, Pg. 1-12
Disk Name: Acad #2661
Filename: WB-Grading BLD
Job No: 516190-6992



Grading, Drainage, Erosion and Sedimentation Control Plan

WYLIE BRANCH
Topical Trp., Pender Co., North Carolina

Owner/Developer:
Island Creek Developers, LLC
100 Carolina Plantations Boulevard
Jacksonville, North Carolina 28546

DATE: 06/16/17
SCALE: 1"=60'

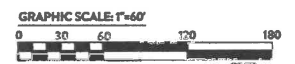

PARKER & ASSOCIATES, INC.
Consulting Engineers - Land Surveyors - Land Planners
Jacksonville, North Carolina
P.O. Box 976 - 28541-0976 306 New Bridge Street - 28540
Phone (910) 455-2414 - Fax (910) 455-3441
Firm License Number: F-0108



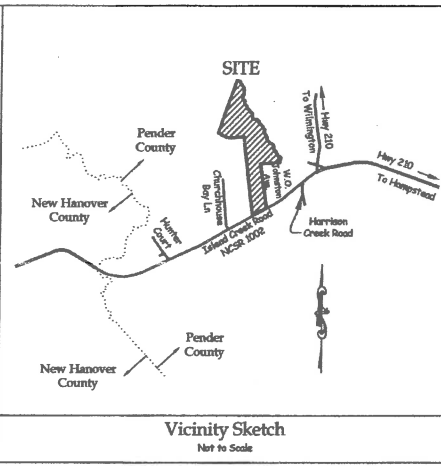
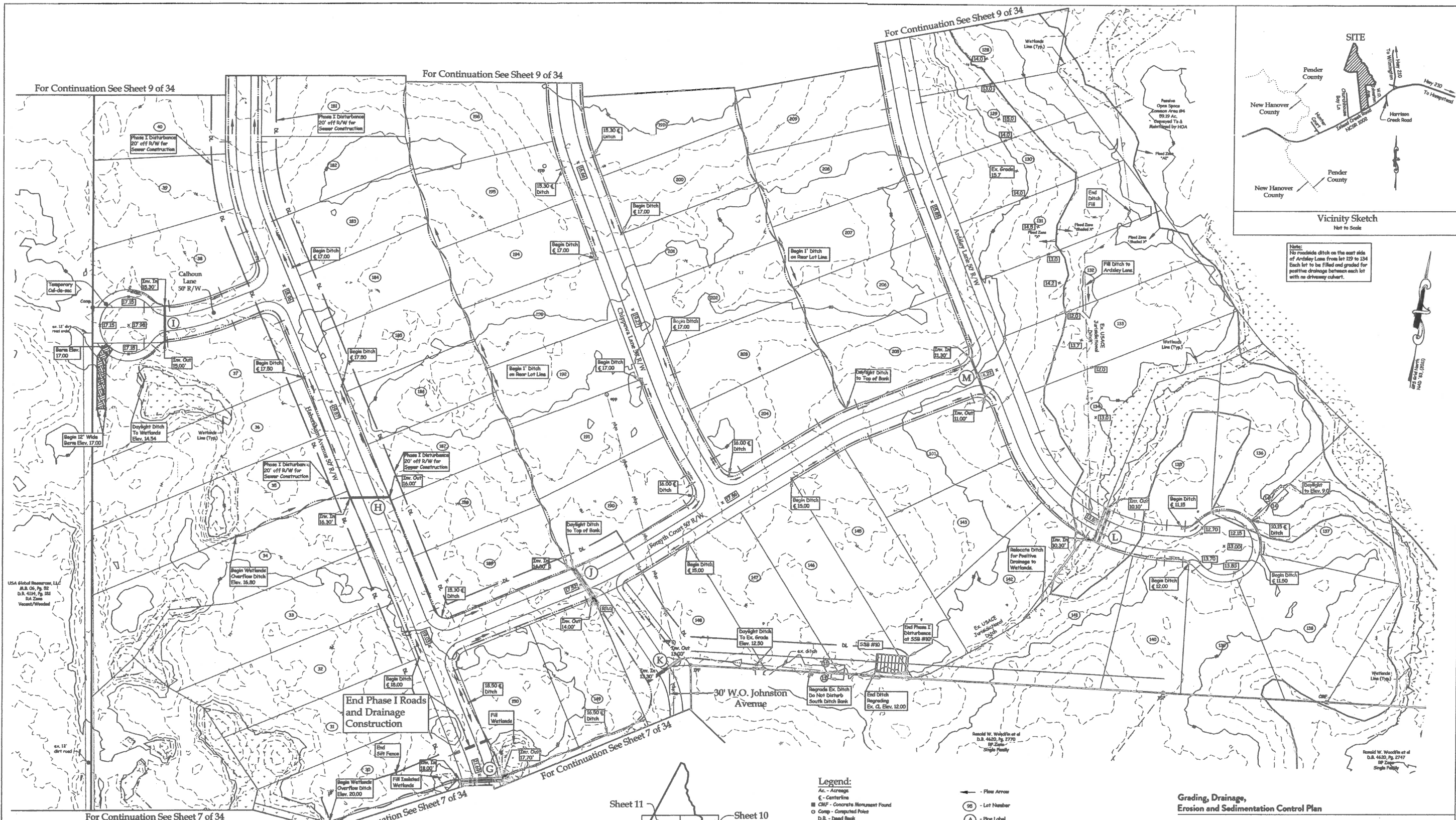

Note:
Contractor shall insure that he and all his workers (contractors, subcontractors and other site personnel) do not damage construction stakes or other measures used in laying out the project whether by the Engineer or another entity including those under the employ of the contractor. Contractor shall cause his workers to observe and verify to the fullest extent practicable that stakes, other measures and grades are, or appear to be, accurate and correct, and immediately, but prior to any associated work, notify the staging entity of any potential conflict, error or question regarding the work. The Engineer shall not be responsible if all of the above measures are not strictly adhered to. The Engineer shall not be responsible where due to damage, his staging can not be verified. For critical or costly components of the work, where the contractor believes that staking may not be preserved, the contractor shall request the staging entity to place staking in an area where its preservation can be insured.

PHASE I LAND DISTURBANCE:	
Roads, Drains, and Lots 1-29 and 150-181	- 33.8 Ac.
Offsite Sewer	- 18.4 Ac.
Total	- 52.2 Ac.

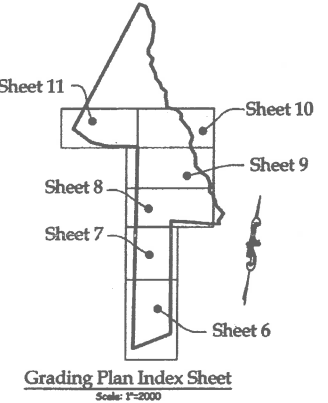

- Legend:**
- Ac. - Acreage
 - C - Contour
 - CMF - Concrete Monument Found
 - Comp - Computed Point
 - D.B. - Dated Book
 - Ex. - Existing
 - HOA - Home Owners Association
 - In. - Invert
 - M.B. - Map Book
 - Pg. - Page
 - R/W - Right-of-way
 - RCO - Rock Check Dam
 - RDA - Rip Rap Apron
 - SST - Sediment Trap
 - Typ. - Typical
- Flow Arrow
 - Lot Number
 - Pipe Label
 - Proposed Spot Elevation
 - Wetlands
 - Existing Ditch/Scale
 - Proposed Ditch/Scale
 - Silt Fence
 - Wetlands Line



Grading, Drainage, Erosion and Sedimentation Control Plan

WYLIE BRANCH
Topsail Trp., Pender Co., North Carolina

Owner/Developer:
Island Creek Developers, LLC
100 Carolina Plantations Boulevard
Jacksonville, North Carolina 28546

DATE: 06/16/17
SCALE: 1"=60'

GRAPHIC SCALE 1"=60'
0 30 60 120 180 FEET

PARKER & ASSOCIATES, INC.
Consulting Engineers - Land Surveyors - Land Planners
Jacksonville, North Carolina
P.O. Box 976 - 28541-0976 306 New Bridge Street - 28540
Phone (910) 455-2414 - Fax (910) 455-3441
Firm License Number: F-0108

Sheet 8 of 34

Z:\MFC\CAD Civil 3D\1218 Ac Thorn10\WV\WB - 10.dwg, 2/16/2018 9:51:23 AM, BLD

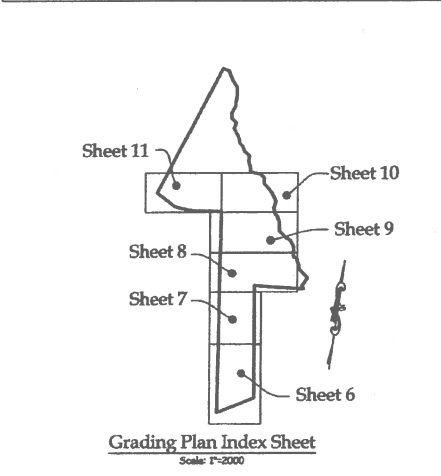
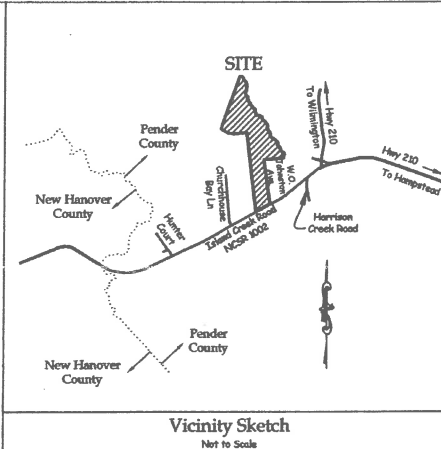
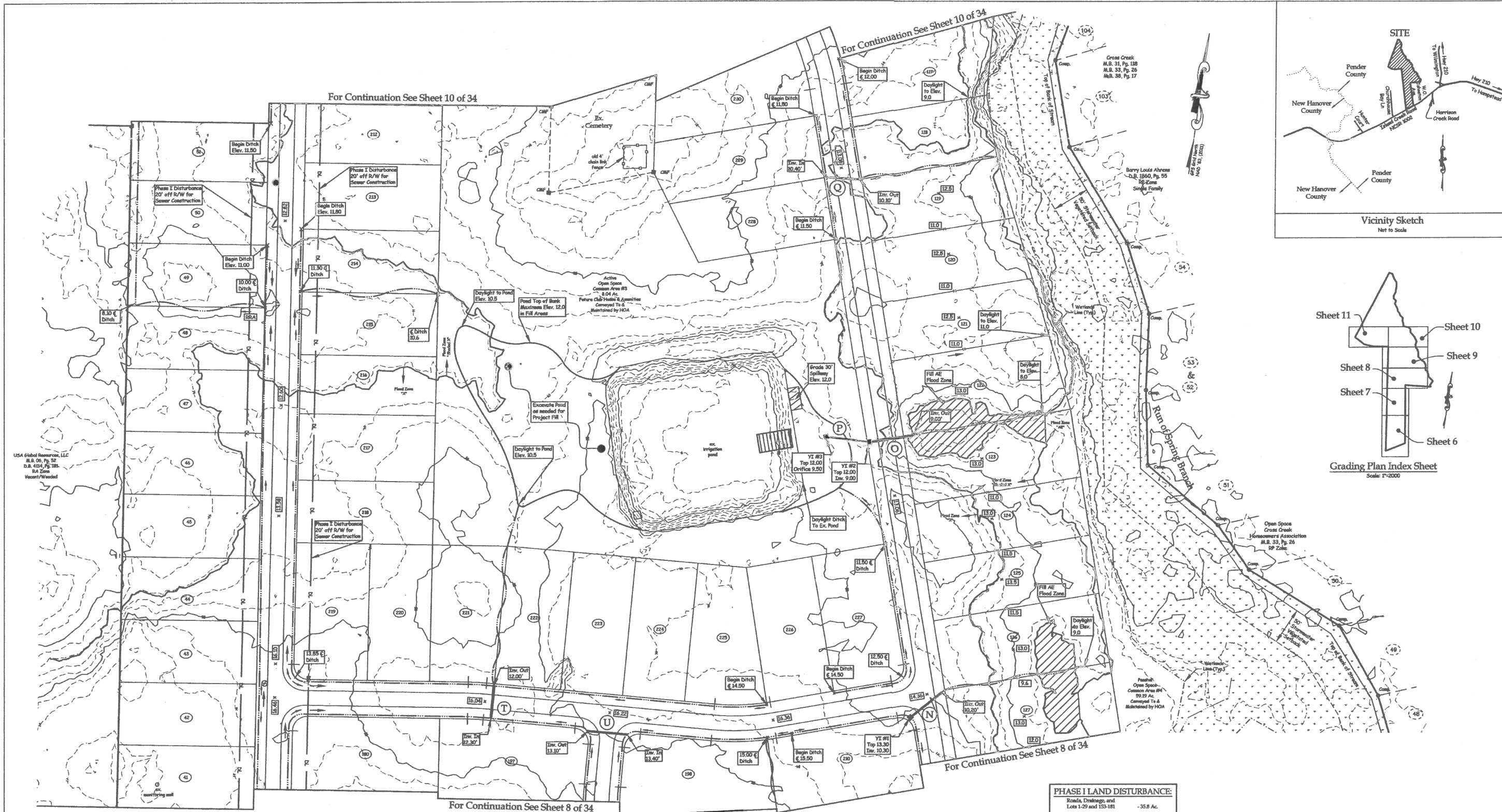

PHASE I LAND DISTURBANCE:

Roads, Drainage, and Lots 1-29 and 153-181	- 35.8 Ac.
Offsite Sewer	- 18.4 Ac.
Total	- 54.2 Ac.

Grading, Drainage, Erosion and Sedimentation Control Plan

WYLIE BRANCH
Topail Trp., Pender Co., North Carolina

Owner/Developer: **Island Creek Developers, LLC**
100 Carolina Plantations Boulevard
Jacksonville, North Carolina 28546

DATE: 06/16/17

SCALE: 1"=60'



PARKER & ASSOCIATES, INC.
Consulting Engineers - Land Surveyors - Land Planners
Jacksonville, North Carolina
P.O. Box 976 - 28541-0976 306 New Bridge Street - 28540
Phone (910) 455-2414 - Fax (910) 455-3441
Firm License Number: F-0108



Note:
Contractor shall insure that he and all his workers (contractors, subcontractors and other site personnel) do not damage construction shales or other measures used in laying out the project whether by the Engineer or another entity including those under the employ of the contractor. Contractor shall cause his workers to observe and verify to the fullest extent practicable that stakes, other measures and grades are, or appear to be, accurate and correct, and immediately, but prior to any associated work, verify the staking entity of any potential conflict, error or question regarding the work. The Engineer shall not be responsible if all of the above measures are not strictly adhered to. The Engineer shall not be responsible where due to damage, his staking was not verified. For critical or costly components of the work, where the contractor believes that staking may not be preserved, the contractor shall request the staking entity to place staking in an area where its preservation can be insured.

- Legend:**
- Ac. - Acreage
 - ⊕ - Centerline
 - CMP - Concrete Manassent Found
 - Comp - Computed Point
 - D.B. - Dead Bank
 - EQP - Edge of Pavement
 - Exc. - Existing
 - HQA - Home Owners Association
 - Inv. - Invert
 - M.B. - Map Book
 - Pg. - Page
 - R/W - Right-of-way
 - RCD - Rock Check Dam
 - RRA - Rip Rap Apron
 - ST - Sediment Trap
 - Typ. - Typical
 - WMSO - Wire Mesh Stone Outlet
 - (100) - Existing Lot Number
 - - Flow Arrow
 - 95 - Lot Number
 - A - Pipe Label
 - 12.00 - Proposed Spot Elevation
 - Wetlands
 - Existing Ditch/Scale
 - - - Proposed Ditch/Scale
 - - - Silt Fence
 - - - Wetlands Line

Note:
No roadside ditch on the east side of Ardeley Lane from lot 119 to 134. Each lot to be filled and graded for positive drainage between each lot with no driveway culvert.

Rev. 02/16/18 BLD/104W - Revised layout for sewer
Rev. 10/11/17 BLD - Revised Lots 85 and 86, Revised Pipe J, Revised Wetlands, Revised Lot Numbers
Rev. 08/10/17 BLD - Revised Per NCEDEQ Erosion Control
Rev. 07/19/17 BLD - Revised For Erosion Control Submittal
Rev. 07/10/17 BLD - Revised Grading Plan Index and Add Stormwater Vegetated Setback
Rev. 07/06/17 BLD - Revised Per Final Design

Field Book: Wylie Branch, Pg. 1-12
Disk Number: Amd 23661
Filename: WB-Grading BLD
Job No.: 581630-6392

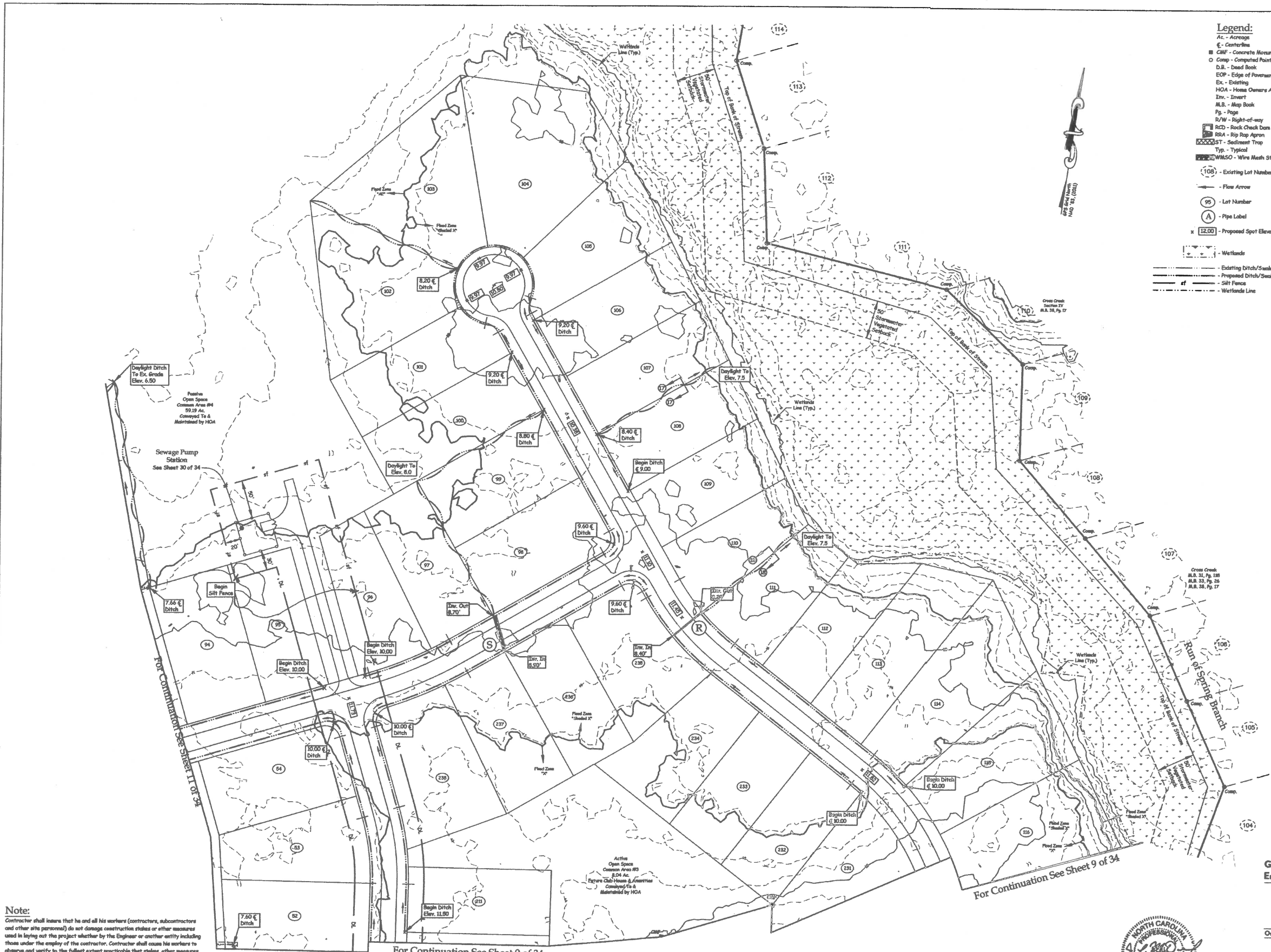

- Legend:**
- Ac. - Acreage
 - g - Centerline
 - CMF - Concrete Monument Found
 - Comp - Contingent Point
 - D.B. - Dead Book
 - EOP - Edge of Pavement
 - Exc. - Existing
 - HOA - Home Owners Association
 - Inv. - Invert
 - M.B. - Map Book
 - Pg. - Page
 - R/W - Right-of-way
 - RCD - Rock Check Dam
 - RQA - Rip Rap Apron
 - ST - Sediment Trap
 - Typ. - Typical
 - WASO - Wire Mesh Stone Outlet
 - 108 - Existing Lot Number
 - 95 - Lot Number
 - A - Pipe Label
 - x 12.00 - Proposed Spot Elevation
 - Wetlands
 - Existing Ditch/Swale
 - Proposed Ditch/Swale
 - sf - Silt Fence
 - Wetlands Line

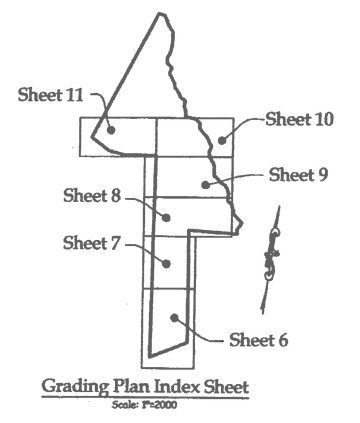
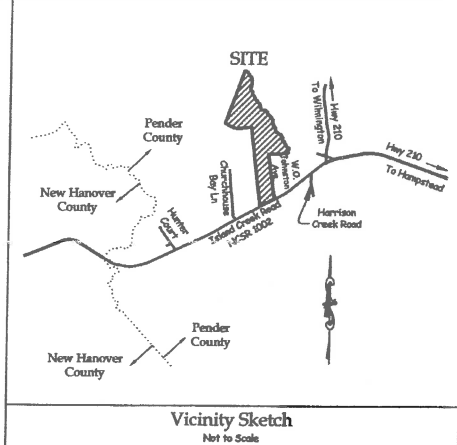

Note:
Contractor shall insure that he and all his workers (contractors, subcontractors and other site personnel) do not damage construction stakes or other measures used in laying out the project whether by the Engineer or another entity including those under the employ of the contractor. Contractor shall cause his workers to observe and verify to the fullest extent practicable that stakes, other measures and grades are, or appear to be, accurate and correct, and immediately, but prior to any associated work, notify the staging entity of any potential conflict, error or question regarding the work. The Engineer shall not be responsible if all of the above measures are not strictly adhered to. The Engineer shall not be responsible where due to damage, his staging can not be verified. For critical or costly components of the work, where the contractor believes that staking may not be preserved, the contractor shall request the staging entity to place staking in an area where its preservation can be insured.

Rev. 02/16/18 JJS - Revised for sewer design
 Rev. 10/11/17 BLD - Revised Lots 85 and 86, Revised Pigs J, Revised Wetlands, Revised Lot Numbers
 Rev. 06/10/17 BLD - Revised Per NCDJSC Erosion Control
 Rev. 07/19/17 BLD - Revised For Erosion Control Submittal
 Rev. 07/10/17 BLD - Revised Grading Plan Index and Add Stormwater Vegetated Setback
 Rev. 07/06/17 BLD - Revised Per Final Design

PHASE I LAND DISTURBANCE:	
Roads, Drainage, and Lots 1-29 and 153-181	- 35.8 Ac.
Offsite Sewer	- 18.6 Ac.
Total	- 54.2 Ac.



Grading, Drainage,
Erosion and Sedimentation Control Plan

WYLIE BRANCH
Topsoil Trp., Pender Co., North Carolina

Owner/Developer:
Island Creek Developers, LLC
100 Carolina Plantations Boulevard
Jacksonville, North Carolina 28546

DATE: 06/16/17
SCALE: 1"=60'



PARKER & ASSOCIATES, INC.
Consulting Engineers - Land Surveyors - Land Planners
Jacksonville, North Carolina
P.O. Box 976 - 28541-0976 306 New Bridge Street - 28540
Phone (910) 455-2414 - Fax (910) 455-3441
Firm License Number: F-0108



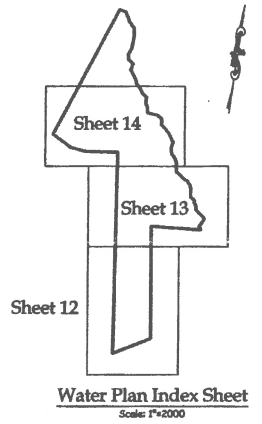

Water Plan Index Sheet
Scale: 1"=200'

- Legend:**
- Ac. - Acreage
 - BO - Blow Off
 - CAF - Concrete Manhole Found
 - CD - Cleanout
 - Comp - Computed Point
 - D.B. - Dead Book
 - DI - Ductile Iron
 - efh - Existing Fire Hydrant
 - egp - Existing Gate Valve
 - EOP - Edge of Pavement
 - epb - Existing Power Box
 - epw - Existing Power Pole
 - Ex. - Existing
 - FH - Fire Hydrant
 - GV - Gate Valve
 - HOA - Home Owners Association
 - IPF - Iron Pipes Found
 - ISF - Iron Strakes Found
 - M.B. - Map Book
 - MH - Manhole
 - Pg. - Page
 - P.T. - Plug Tapped
 - R/W - Right-of-way
 - Typ. - Typical
- Flow Arrow
 - Lot Number
 - Wetlands
 - Existing Waterline
 - Offsite Septic Supply Line
 - Overhead Power Line
 - Proposed Waterline
 - Wetlands Line

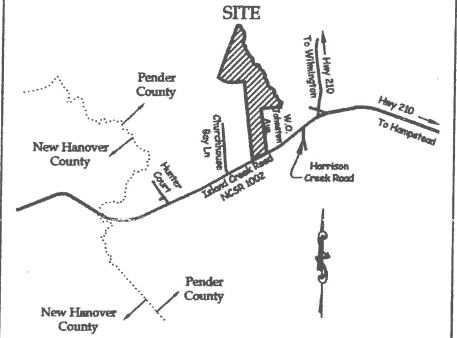

Vicinity Sketch
Not to Scale

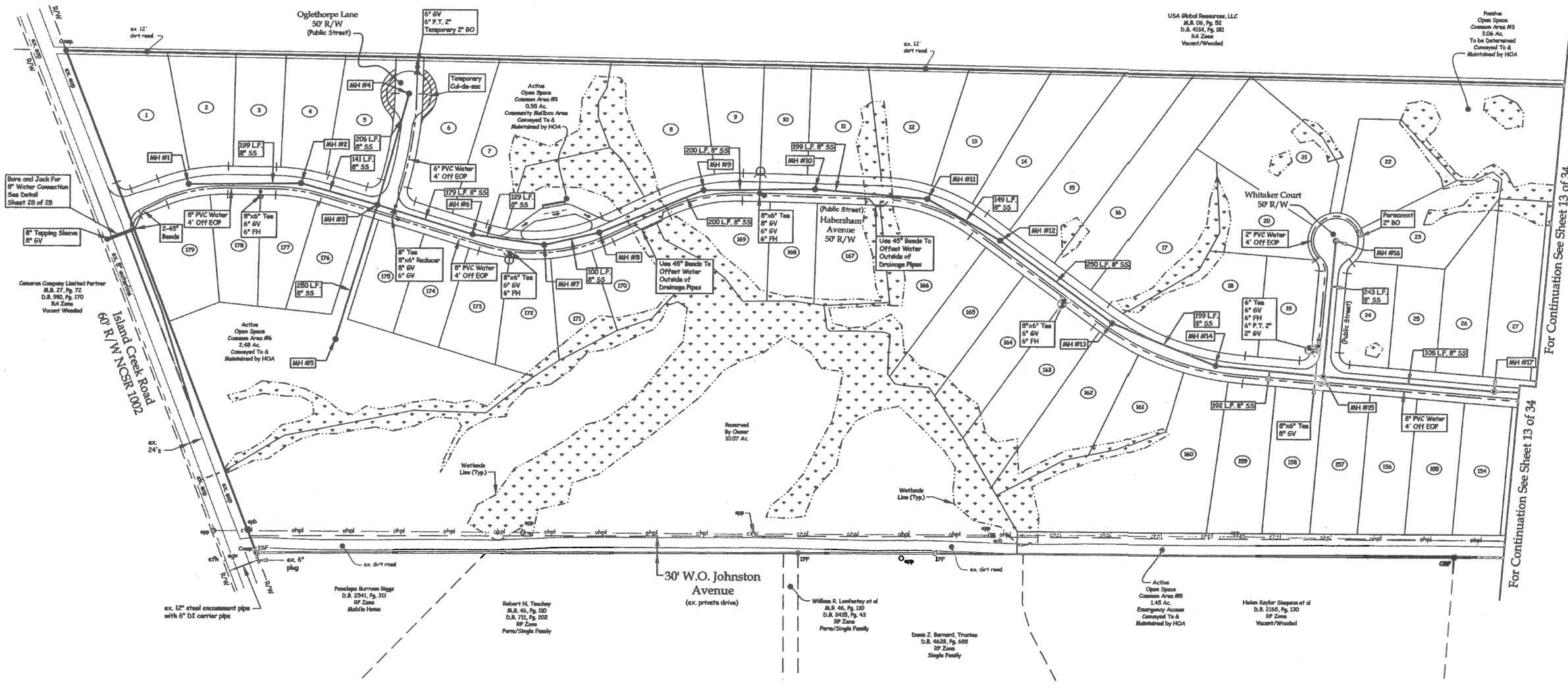

- Water and Sewer Notes:**
1. Potable water supply to be by Pender County Utilities (PCU).
 2. Wastewater treatment to be by Paris Homestead, LLC.
 3. As of October 1, 2014, anyone digging with mechanical equipment in highway right-of-way, private utility easements, or public spaces will be required by North Carolina law to give notice of the proposed excavation to all existing area utilities at least three to twelve business days before starting to dig. The utility owner is to locate its facilities in the area of the proposed excavation. Utility members of North Carolina 811 can be contacted at 1-800-632-6949.
 4. Locations and elevations of existing water mains and all utilities are approximated and shall be verified by contractor prior to construction.
 5. Contractor is responsible for any damages to any existing utilities.
 6. All proposed sewer mains shall be 8, 10, or 12-inch PVC SDR35 or Ductile Iron as shown on the plans. Services to be 4-inch Sch. 40 PVC or Ductile Iron.
 7. All manholes located outside of street right-of-ways shall have watertight rings & covers.
 8. All water mains shall be ASTM D-2241, PVC 1120, SDR 21, 200 PSI pressure rating.
 9. Fire hydrants to be manufactured by American Daring or approved equal.
 10. Water mains shall be buried with minimum of 36-inch cover, unless otherwise noted.
 11. Contractor to lay water mains at extra depth to avoid conflicts with storm drainage or other facilities.
 12. Water mains & sewer mains shall have proper separations. At water & sewer crossings, the water main shall have 18 inch minimum separation above the sewer main or they both shall be constructed of ferrous material for a minimum of 30 feet each side of the crossing. See specifications for further details.
 13. Contractor shall notify the Engineer, Paris, and PCU at least 48 hours prior to commencing any work, inspections, sampling, and pressure tests.
 14. Chlorination and pressure tests are required in the presence of the Engineer, Paris, and PCU.
 15. Contractor shall furnish negative bacterial analysis results and 24 hour chlorine residual reports to the certifying Engineer.
 16. Sewer Mains shall be low pressure air tested and manholes shall be vacuum tested. Tests are required in the presence of the certifying Engineer.
 17. Contractor shall maintain comprehensive (depth and horizontal location) field "As Built" for all installations and submit them to the certifying Engineer and PCU.
 18. All water shall have individual water & sewer services installed by the contractor.
 19. All water systems installation materials and practices shall meet PCU specifications.
 20. For other detailed construction notes, see plans and profiles, and specifications.
 21. All construction within NCDOT right-of-way shall be in accordance with the NCDOT requirements. NCDOT officials shall be notified 48 hours prior to commencing work within the right-of-way.
 22. All sewer systems installation materials & practices shall meet Paris standards and specifications.
 23. No construction of either water or sewer main is to begin prior to receipt of permits to construct from NCDENR in accordance with 15A NCAC18C.0308 (a) and 15A NCA02H.0204.
 24. Water mains shall be 4' off edge of pavement.
 25. Coordinate preconstruction meeting with Engineer, Paris, and Pender County Utilities before contractor orders materials and begins construction.
 26. Install gate valves and one joint of water main at end of all phase lines.
 27. All pipe fittings to be mechanical joint with grip rings.
 28. All gate valves to be located outside of roadway to the greatest extent possible. To be discussed during preconstruction meeting.
 29. All utility crossings shall be coordinated with Paris and PCU at a pre-construction meeting prior to beginning construction.
 30. Coordinate tapping sleeves, and bore and jack details with PCU at Pre-Construction Meeting.
 31. PCU Standard Notes:
 - A. A preconstruction meeting is required before beginning work. The meeting must be scheduled with Pender County Utilities (PCU) at least one week in advance. Attendees must include PCU, The Selected Contractor's Superintendent, The Supplier, and The Consulting Engineer.
 - B. All materials used shall conform to Pender County Utilities requirements. Non-conforming material will not be accepted for final certification.
 - C. All pipe shall be pvc. PVC pipe with a coating to be C900 DR18 (See PCU Standard Detail). All other pvc pipe to be SDR 21. The use of DIP pipe is not allowed. PCU must approve the use of DIP in the field before installation and only when there are no other options.
 - D. PCU standard waterline pipe restraining method is A17 Grip Rings. At a minimum of fittings, valves, ETC. Must be Restrainted. (See PCU Standard Detail).
 - E. PCU must inspect casing installations prior to back-fill. PCU must witness pressure tests, and withdrawal of bacteriological samples. Contact Bob Ford at schedule 910-259-0222.
 - F. Check-out documents which must be received prior to PCU signing the NC PWSS Applicant Certification include: Bacteriological Tests, Pressure Tests, Dead of Dedication, Affidavit/Release of Liens, Warranty, and Record Drawings (PDF & CAD).
 - G. An 18 month warranty period applies to all waterline construction until final approval of the system has been received from NC PWSS.

Note:
Contractor shall insure that he and all his workers (contractors, subcontractors and other site personnel) do not damage construction shoring or other measures used in laying out the project whether by the Engineer or another entity including those under the employ of the contractor. Contractor shall cause his workers to observe and verify to the fullest extent practicable that stakes, other measures and grades are, or appear to be, accurate and correct, and immediately, but prior to any associated work, notify the staking entity of any potential conflict, error or question regarding the work. The Engineer shall not be responsible if all of the above measures are not strictly adhered to. The Engineer shall not be responsible where due to damage, his staking can not be verified. For critical or costly components of the work, where the contractor believes that staking may not be preserved, the contractor shall request the staking entity to place staking in an area where its preservation can be insured.

- General Notes:**
1. Existing Waterlines on Island Creek Road Taken from Plans Entitled "8" PVC Water Line 3002 Island Creek Road Sta. 13+00 to Sta. 4+00 (and Sta. 4+00 to Sta. 64+00) Dated 03-29-07 by McKim & Creed.

Water & Sewer Plan

WYLIE BRANCH
Topsoil Typ., Pender Co., North Carolina

Owner/Developer:
Island Creek Developers, LLC
100 Carolina Plantations Boulevard
Jacksonville, North Carolina 28546

DATE: 06/16/17
SCALE: 1"=100'

GRAPHIC SCALE: 1"=100'
0 50 100 200 300 FEET

PARKER & ASSOCIATES, INC.
Consulting Engineers - Land Surveyors - Land Planners
Jacksonville, North Carolina
P.O. Box 976 - 28541-0976 - 306 New Bridge Street - 28540
Phone (910) 455-2414 - Fax (910) 455-3441
Firm License Number: F-0108



Rev. 02/16/18 BLD/30'W - Revises layout for sewer
Rev. 10/11/17 BLD - Label Blow-offs as Temporary or Permanent Per PCU Comments, Revises Bore Location, Revises Lot Numbers, Add Street Casing For Driveway Sewer
Rev. 06/07/17 BLD - Revises Per Septic Design and PAT Revisions

Field Book: Wylie Branch, Pg 1-12
Disk Name: Acad 42661
Filename: WB-Gouging BLD
Job No: 595700-6372

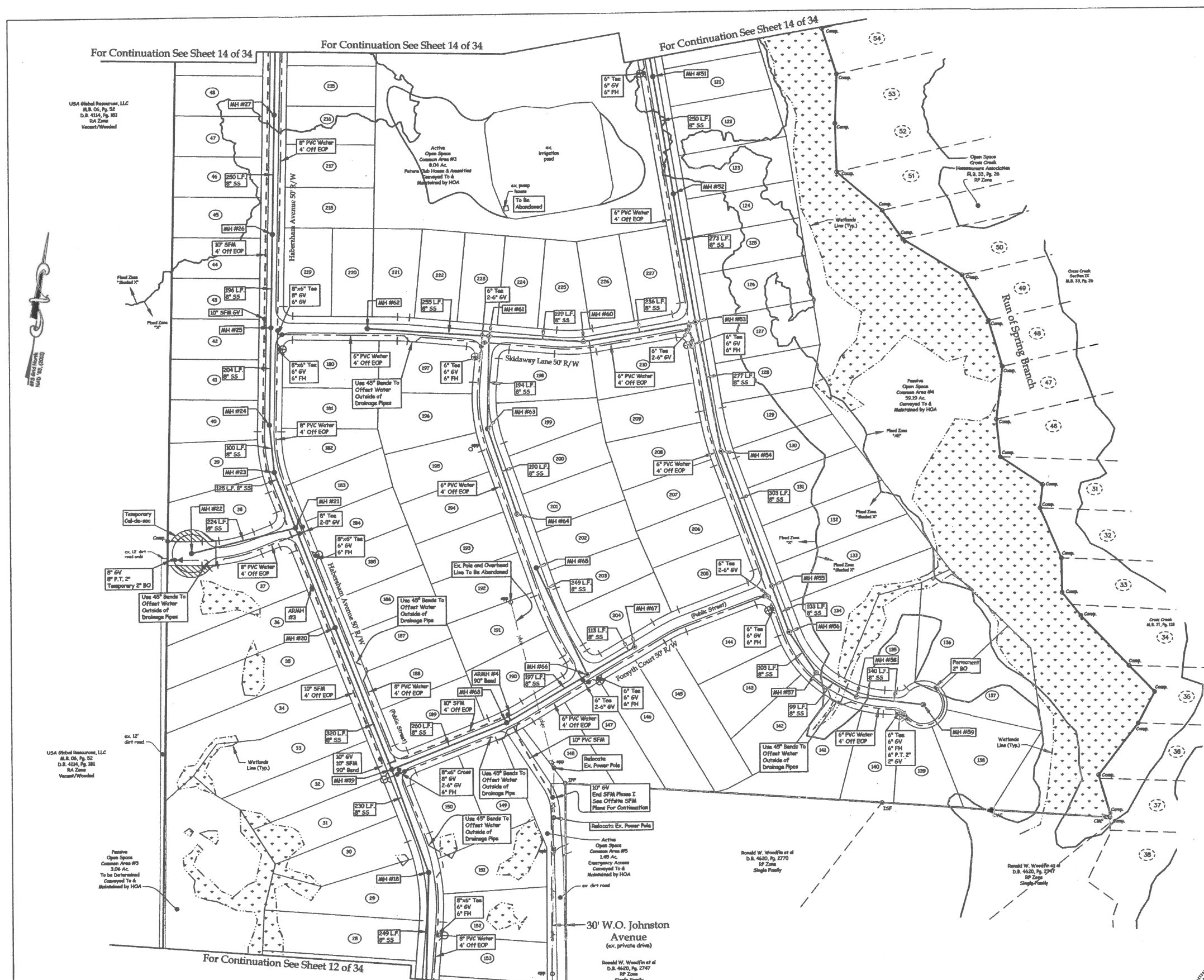

- Legend:**
- Ac - Acreage
 - BO - Blow Off
 - CMF - Concrete Monument Found
 - CO - Cleanout
 - Comp - Computed Point
 - D.B. - Deed Book
 - EOP - Edge of Pavement
 - EPB - Existing Power Box
 - Exp - Existing
 - Ex - Existing
 - FH - Fire Hydrant
 - GV - Gate Valve
 - HOA - Home Owners Association
 - IFP - Iron Pipe Found
 - ISP - Iron Pipe Found
 - M.B. - Map Book
 - MH - Manhole
 - PG - Flag
 - P.T.T. - Flag Topped
 - R/W - Right-of-way
 - Typ - Typical
 - 50 - Existing Lot Number
 - 121 - Lot Number
 - Wetlands
 - Offsite Septic Supply Line
 - Overhead Power Line
 - Proposed Waterline
 - Wetlands Line

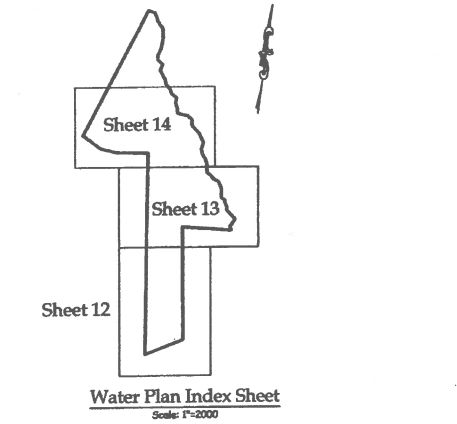
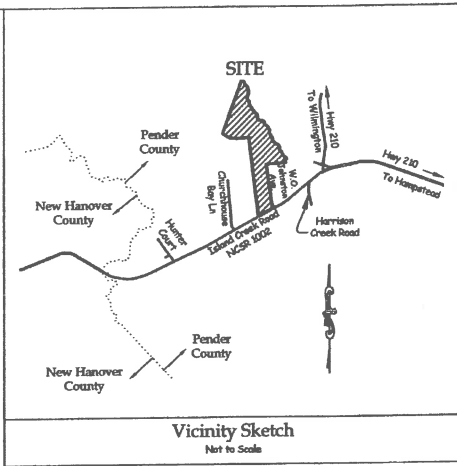

USA Global Resources, LLC
A.B. 06, Pg. 52
D.B. 4134, Pg. 383
RA Zone
Vacant/Wooded

USA Global Resources, LLC
A.B. 06, Pg. 52
D.B. 4134, Pg. 381
RA Zone
Vacant/Wooded

Active Open Space
Common Area #3
8.04 Ac.
Permits Old Homes & Associates
Conveyed To &
Maintained by HOA

Active Open Space
Common Area #4
59.39 Ac.
Conveyed To &
Maintained by HOA

Active Open Space
Common Area #5
1.40 Ac.
Emergency Access
Conveyed To &
Maintained by HOA

Active Open Space
Common Area #6
3.04 Ac.
To Be Determined
Conveyed To &
Maintained by HOA

Active Open Space
Common Area #7
1.40 Ac.
Emergency Access
Conveyed To &
Maintained by HOA

Note:
Contractor shall insure that he and all his workers (contractors, subcontractors and other site personnel) do not damage construction stakes or other markers used in laying out the project whether by the Engineer or another entity including those under the employ of the contractor. Contractor shall cause his workers to observe and verify to the fullest extent practicable that stakes, other markers and grades are, or appear to be, accurate and correct, and immediately, but prior to any associated work, notify the staking entity of any potential conflict, error or question regarding the work. The Engineer shall not be responsible if all of the above markers are not strictly adhered to. The Engineer shall not be responsible where due to damage, his staking can not be verified. For critical or costly components of the work, where the contractor believes that staking may not be preserved, the contractor shall request the staking entity to place staking in an area where its preservation can be insured.

Rev. 02/16/18 BLD/10/W - Revis layout for sewer
Rev. 10/11/17 BLD - Label Blow-offs as Temporary or Permanent Per POU Comments, Revise Wetlands,
Revise Lot Numbers, Add Steel Casing For Gravity Sewer
Rev. 06/07/17 BLD - Revise Per Septic Design and P&S Review



Water & Sewer Plan
WYLIE BRANCH
Topsail Trp., Pender Co., North Carolina

Owner/Developer:
Island Creek Developers, LLC
100 Carolina Plantations Boulevard
Jacksonville, North Carolina 28546

DATE: 06/16/17
SCALE: 1"=100'

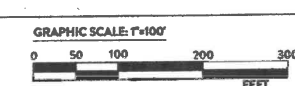

PARKER & ASSOCIATES, INC.
Consulting Engineers - Land Surveyors - Land Planners
Jacksonville, North Carolina
P.O. Box 976 - 28541-0976 306 New Bridge Street - 28540
Phone (910) 455-2414 - Fax (910) 455-3441
Firm License Number: F-0108

Field Book: Wylie Branch, Pg. 1-12
Disk Name: Acad 02681
Filename: WB-Gis.dwg BLD
Job No.: 58190-6992

Z:\VMS\CAD Civil 3D\1318 Ac Test\DWG\WB - Bld.dwg, 2/16/2018 8:46:24 AM, BLD

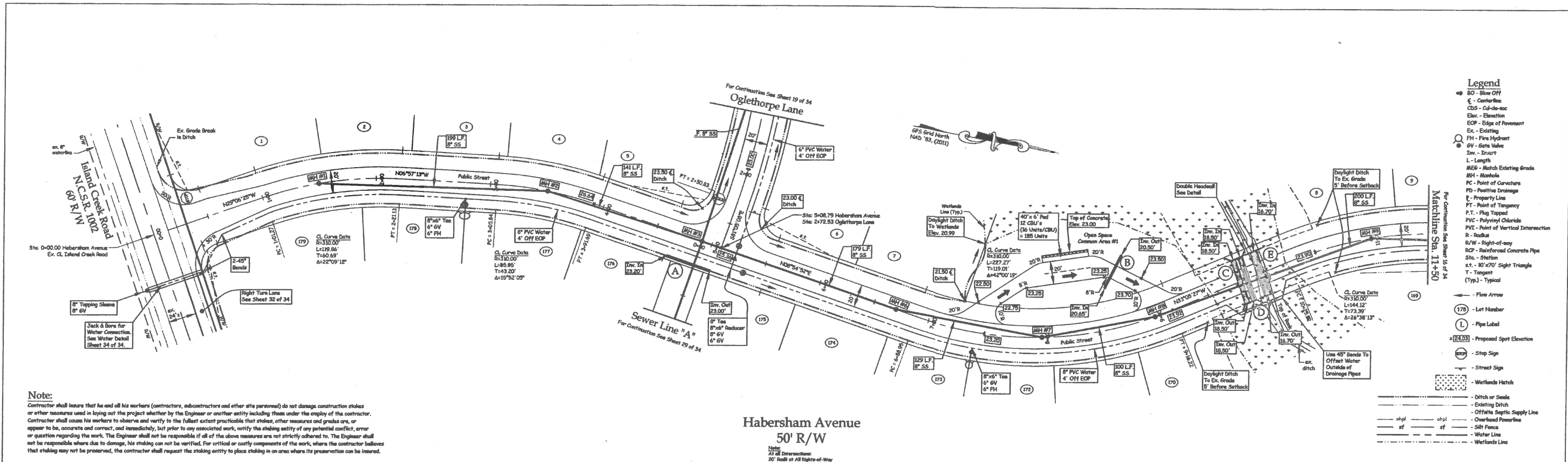

- Legend**
- BO - Blow Off
 - CL - Centerline
 - CDS - Call-to-action
 - Elev. - Elevation
 - EOB - Edge of Pavement
 - Ex. - Existing
 - FH - Fire Hydrant
 - GV - Gate Valve
 - Inv. - Invert
 - L - Length
 - MEG - Match Existing Grade
 - MH - Manhole
 - PC - Point of Curvature
 - PD - Positive Drainage
 - PL - Property Line
 - PT - Point of Tangency
 - P.T. - Flag Tapped
 - PVC - Polyvinyl Chloride
 - PVT - Point of Vertical Intersection
 - R - Radius
 - R/W - Right-of-way
 - SCP - Reinforced Concrete Pipe
 - Sta. - Station
 - s.t. - 10'/10' Sight Triangle
 - T - Tangent
 - (Typ.) - Typical
- Flow Arrow
- 179 - Lot Number
- L - Pipe Label
- 23.00 - Proposed Spot Elevation
- Stop Sign
- Street Sign
- Wetlands Hatch
- Ditch or Smile
- Existing Ditch
- Off-site Septic Supply Line
- Overhead Powerline
- Silt Fence
- Water Line
- Wetlands Line

Note:
Contractor shall insure that he and all his workers (contractors, subcontractors and other site personnel) do not damage construction stakes or other measures used in laying out the project whether by the Engineer or another entity including those under the employ of the contractor. Contractor shall cause his workers to observe and verify to the fullest extent practicable that stakes, other measures and grades are or appear to be, accurate and correct, and immediately, but prior to any associated work, notify the staking entity of any potential conflict, error or question regarding the work. The Engineer shall not be responsible if all of the above measures are not strictly adhered to. The Engineer shall not be responsible where due to damage, his staking can not be verified. For critical or costly components of the work, where the contractor believes that staking may not be preserved, the contractor shall request the staking entity to place staking in an area where its preservation can be insured.

Habersham Avenue
50' R/W

Note:
At all Intersections:
20' Radii at All Right-of-Way
30' Radii at All Edge of Pavement

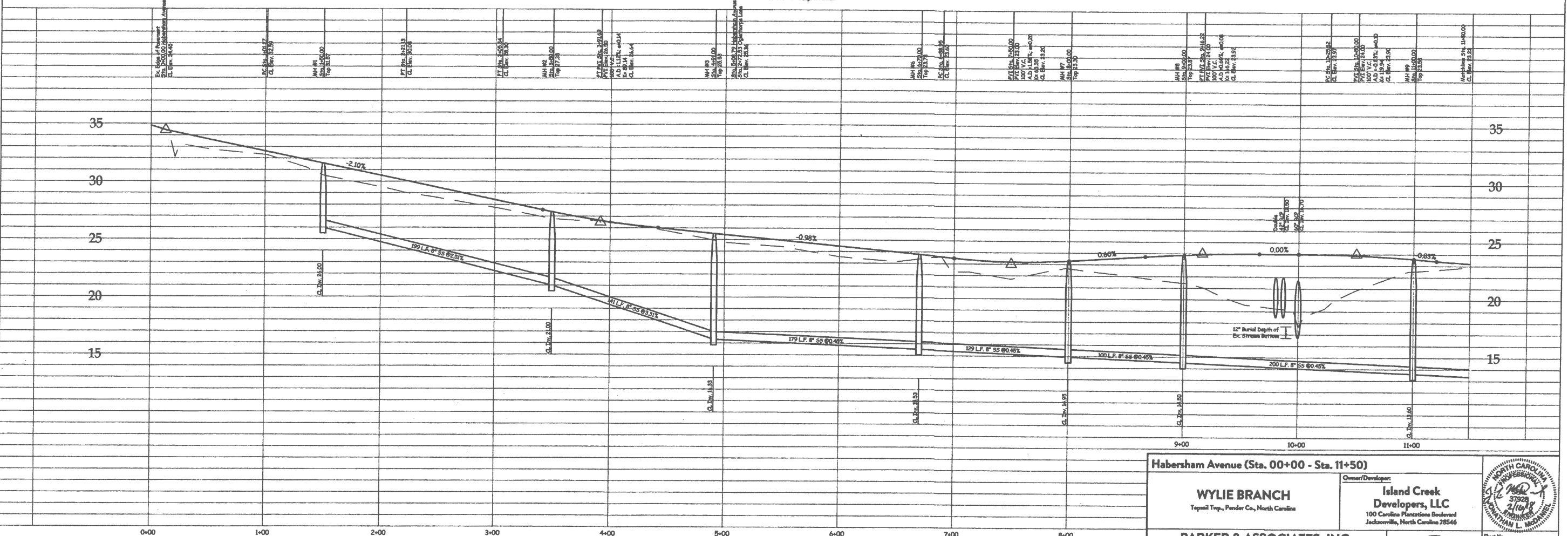

<p>Habersham Avenue (Sta. 00+00 - Sta. 11+50)</p> <p>WYLIE BRANCH Tepail Twp., Pender Co., North Carolina</p>		<p>Owner/Developer: Island Creek Developers, LLC 100 Carolina Plantations Boulevard Jacksonville, North Carolina 28546</p>	
<p>PARKER & ASSOCIATES, INC. Consulting Engineers - Land Surveyors - Land Planners Jacksonville, North Carolina P.O. Box 976 - 28541-0976 306 New Bridge Street - 28540 Phone (910) 455-2434 - Fax (910) 455-3441 Firm License Number: F-0108</p>			<p>Sheet No. 15 of 34</p> <p>Design: JJA Drawn: BLD</p>
Date: 04/16/17	Scale: Vertical 1"=40' Horizontal 1"=40'	Prepared: WB - GMD	<p>Job No.: 576130-6392</p>

Rev. 02/16/18 BLD/10/1W - Revised layout for sewer
Rev. 10/11/17 BLD - Revised Bore Location, Revised Lot Numbers, Add Steel Casing For Gravity Sewer
Rev. 08/07/17 BLD - Revised Per Septic Design and P&E Review

Z:\Users\CAD\OneDrive\WB - bld.dwg, 2/16/2018 8:36:39 AM, BLD

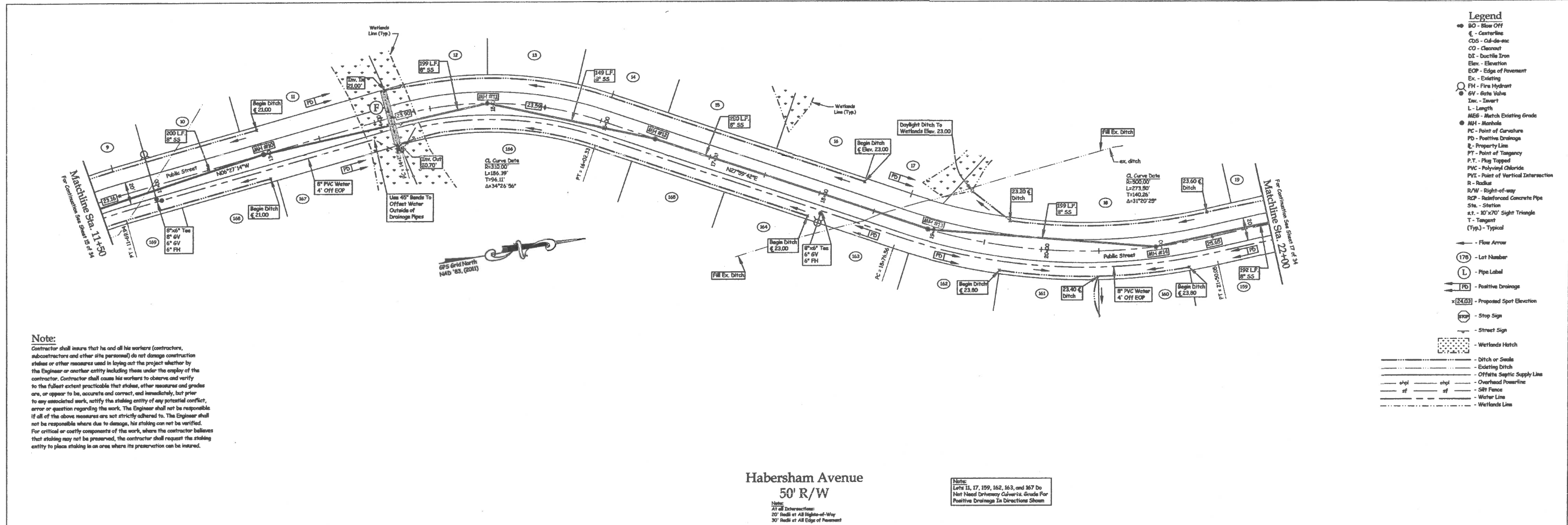

- Legend**
- BO - Blow Off
 - CL - Centerline
 - CO - Cleanout
 - CO - Cleanout
 - DE - Ductile Iron
 - Elev. - Elevation
 - EQP - Edge of Pavement
 - EX - Existing
 - FH - Fire Hydrant
 - GV - Gate Valve
 - Inv. - Invert
 - Len. - Length
 - ME - Match Existing Grade
 - MH - Manhole
 - PC - Point of Curvature
 - PD - Positive Drainage
 - PL - Property Line
 - PT - Point of Tangency
 - PT - Plug Tapped
 - PVC - Polyvinyl Chloride
 - PVC - Point of Vertical Intersection
 - R - Radius
 - R/W - Right-of-way
 - RCP - Reinforced Concrete Pipe
 - Sta. - Station
 - s.t. - 10'x70' Sight Triangle
 - T - Tangent
 - (Typ.) - Typical
- Flow Arrow
 (170) - Lot Number
 L - Pipe Label
 → Positive Drainage
 x[24.03] - Proposed Spot Elevation
 (STOP) - Stop Sign
 - Street Sign
 [Pattern] - Wetlands Hatch
 --- Ditch or Swale
 --- Existing Ditch
 --- Offsets Septic Supply Line
 o-hpl --- Overhead Powerline
 -sf --- Silt Fence
 --- Water Line
 --- Wetlands Line

Note:
 Contractor shall ensure that he and all his workers (contractors, subcontractors and other site personnel) do not damage construction stakes or other measures used in laying out the project whether by the Engineer or another entity including those under the employ of the contractor. Contractor shall cause his workers to observe and verify to the fullest extent practicable that stakes, other measures and grades are, or appear to be, accurate and correct, and immediately, but prior to any associated work, notify the staging entity of any potential conflict, error or question regarding the work. The Engineer shall not be responsible if all of the above measures are not strictly adhered to. The Engineer shall not be responsible where due to damage, his staking can not be verified. For critical or costly components of the work, where the contractor believes that staking may not be preserved, the contractor shall request the staging entity to place staking in an area where its preservation can be insured.

**Habersham Avenue
 50' R/W**

Note:
 Lots 11, 17, 159, 162, 163, and 167 Do Not Need Driveway Culverts. Grade For Positive Drainage In Directions Shown

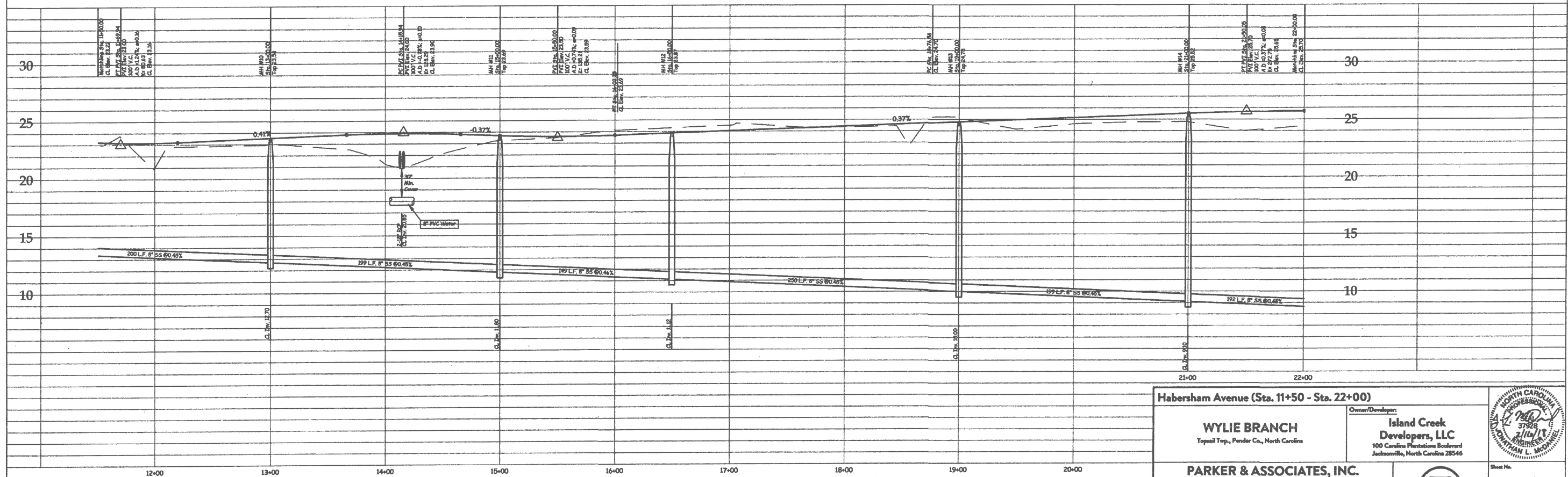

Rev. 02/16/18 BLD/SHW - Review layout for owner
 Rev. 10/11/17 BLD - Review Lot Numbers, Add Street Casing For Gravity Sewer
 Rev. 06/07/17 BLD - Review Per Septic Design and P&I Review

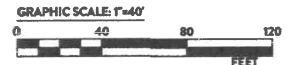

Field Book: Wylie Branch, Pg. 1-12

Habersham Avenue (Sta. 11+50 - Sta. 22+00)		
WYLIE BRANCH Topsail Twp., Pender Co., North Carolina	Island Creek Developers, LLC 100 Carolina Plantations Boulevard Jacksonville, North Carolina 28546	
PARKER & ASSOCIATES, INC. Consulting Engineers - Land Surveyors - Land Planners Jacksonville, North Carolina P.O. Box 976 - 28541-0976 306 New Bridge Street - 28540 Phone (910) 455-2414 - Fax (910) 455-3441 Firm License Number: F-0108		
Date: 06/16/17	Scale: Vertical 1"=40'	Sheet No. 16 of 34
Drawn: BLD	Checked: WB - Gauding	Design: JLM
Date: 06/16/17	Scale: Vertical 1"=40'	Drawn: BLD
Drawn: BLD	Checked: WB - Gauding	Job No.: 516130-4392

Z:\Projects\021618\021618.dwg - 2/16/2018 8:37:18 AM, BLD

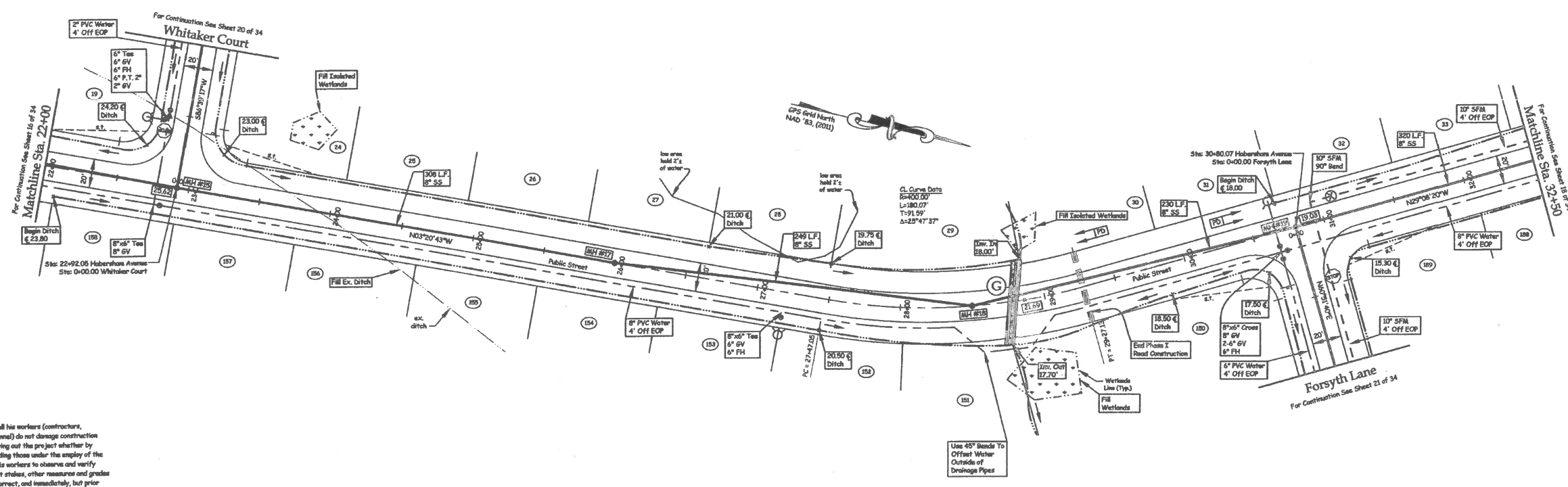

- Legend**
- BO - Blow Off
 - CL - Centerline
 - CD5 - Cut-de-sac
 - Elev. - Elevation
 - EOP - Edge of Pavement
 - Ex. - Existing
 - FH - Fire Hydrant
 - GV - Gate Valve
 - In. - Invert
 - L - Length
 - MEB - Match Entering Grade
 - MH - Manhole
 - PC - Point of Curvature
 - PD - Positive Drainage
 - PL - Property Line
 - PT - Point of Tangency
 - P.T. - Plug Tapped
 - PVC - Polyvinyl Chloride
 - PVI - Point of Vertical Intersection
 - R - Radius
 - R/W - Right-of-way
 - RCP - Reinforced Concrete Pipe
 - Stn. - Station
 - s.t. - 30°/30° Sight Triangle
 - T - Tangent
 - (Typ.) - Typical
- Flow Arrow
 - (178) - Lot Number
 - (L) - Pipe Label
 - PD - Positive Drainage
 - ±24.03 - Proposed Spot Elevation
 - STOP - Stop Sign
 - Street Sign
 - Wetlands Match
 - Ditch or Swale
 - Existing Ditch
 - Overhead Powerline
 - Silt Fence
 - Water Line
 - Wetlands Line

Note:
Contractor shall insure that he and all his workers (contractors, subcontractors and other site personnel) do not damage construction stakes or other measures used in laying out the project whether by the Engineer or another entity including those under the employ of the contractor. Contractor shall cause his workers to observe and verify to the fullest extent practicable that stakes, other measures and grades are, or appear to be, accurate and correct, and immediately, but prior to any associated work, notify the staking entity of any potential conflict, error or question regarding the work. The Engineer shall not be responsible if all of the above measures are not strictly adhered to. The Engineer shall not be responsible where due to damage, his staking can not be verified. For critical or costly components of the work, where the contractor believes that staking may not be preserved, the contractor shall request the staking entity to place staking in an area where its preservation can be insured.

**Habersham Avenue
50' R/W**

Note:
At All Intersections:
20' R/W at All Rights-of-Way
30' Radii at All Edges of Pavement

Note:
Lots 30 and 31 Do Not Need Driveway Culverts. Grade For Positive Drainage In Directions Shown

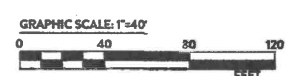
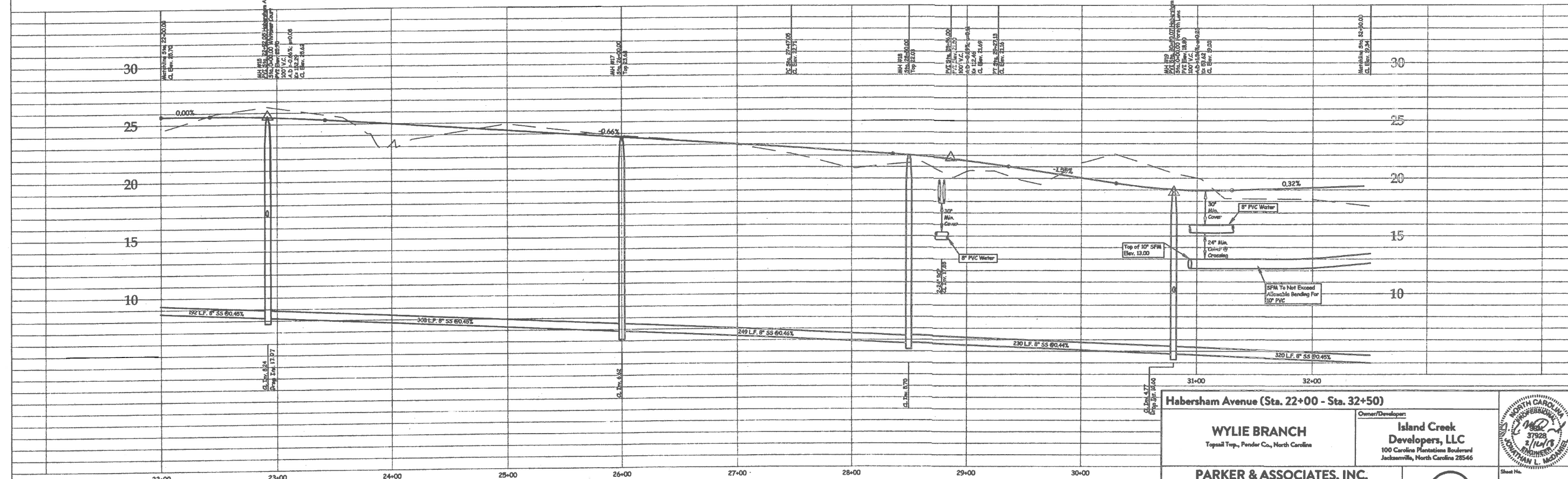

Rev. 02/16/18 BLD/101W - Revise layout for owner
Rev. 10/11/17 BLD - Revise Lot Numbers, Add Steel Casing For Gravity Sewer
Rev. 08/07/17 BLD - Revise Per Septic Design and PAE Review

Habersham Avenue (Sta. 22+00 - Sta. 32+50)		
WYLIE BRANCH Topsail Twp., Pender Co., North Carolina	Island Creek Developers, LLC 100 Carolina Plantations Boulevard Jacksonville, North Carolina 28546	
PARKER & ASSOCIATES, INC. Consulting Engineers - Land Surveyors - Land Planners Jacksonville, North Carolina P.O. Box 976 - 28541-0976 306 New Bridge Street - 28540 Phone (910) 455-2414 - Fax (910) 455-3441 Firm License Numbers: F-0108		Sheet No. 17 of 34 Design: JLM Drawn: BLD Date: 06/16/17 Scale: Vertical 1"=40' Horizontal 1"=40' Firm: WB - Gauding Dwg: Acad R2661 Job No.: S16130-0392

Z:\web\CAD Civil 3D\2018 Ac Theor\DWG\WVF - hldwg_2716\2018 B3603 AM_BLD

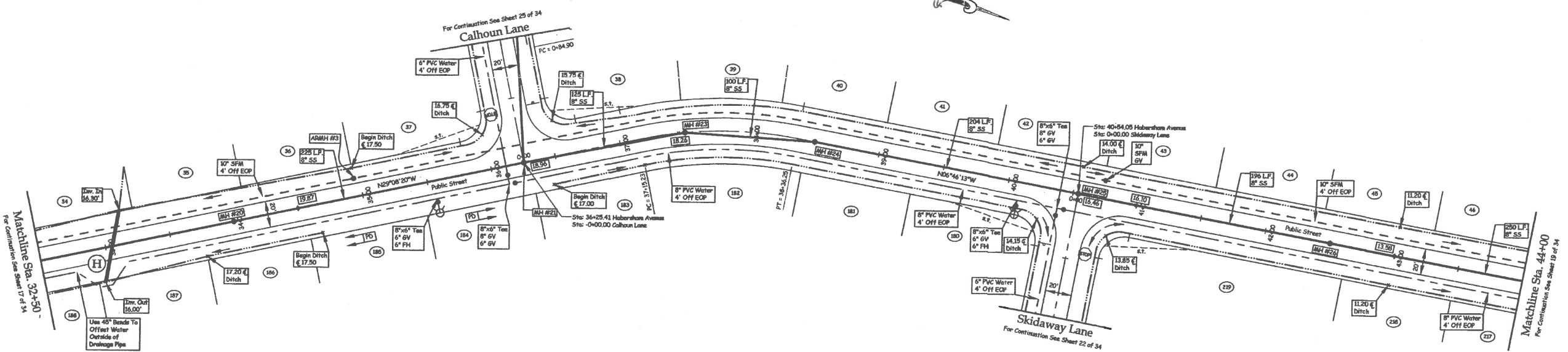

- Legend**
- BO - Slow Off
 - € - Centerline
 - CDS - Cut-de-sac
 - Elev. - Elevation
 - EC - Edge of Pavement
 - EX - Existing
 - FH - Fire Hydrant
 - GV - Gate Valve
 - Inv. - Invert
 - L - Length
 - MES - Match Existing Grade
 - PC - Point of Curvature
 - PD - Positive Drainage
 - PL - Property Line
 - PT - Point of Tangency
 - P.T. - Plug Tapped
 - PVC - Polyvinyl Chloride
 - PVI - Point of Vertical Intersection
 - R - Radius
 - R/W - Right-of-way
 - RCP - Reinforced Concrete Pipe
 - Stn. - Station
 - s.s. - 10'x10' Sight Triangle
 - T - Tangent
 - (Typ.) - Typical
- - Flow Arrow
 - (178) - Lot Number
 - (L) - Pipe Label
 - PD - Positive Drainage
 - (24.03) - Proposed Spot Elevation
 - (STOP) - Stop Sign
 - - Street Sign
 - - Wetlands Hatch
 - - Ditch or Swale
 - - Existing Ditch
 - - Overhead Powerline
 - - Silt Fence
 - - Water Line
 - - Wetlands Line

Note:
Contractor shall insure that he and all his workers (contractors, subcontractors and other site personnel) do not damage construction stakes or other measures used in laying out the project whether by the Engineer or another entity including those under the employ of the contractor. Contractor shall cause his workers to observe and verify to the fullest extent practicable that stakes, other measures and grades are, or appear to be, accurate and correct, and immediately, but prior to any associated work, notify the staking entity of any potential conflict, error or question regarding the work. The Engineer shall not be responsible if all of the above measures are not strictly adhered to. The Engineer shall not be responsible where due to damage, his staking can not be verified. For critical or costly components of the work, where the contractor believes that staking may not be preserved, the contractor shall request the staking entity to place staking in an area where its preservation can be insured.

**Habersham Avenue
50' R/W**

Note:
Lots 184 and 185 Do Not Need Driveway Culverts. Grade For Positive Drainage In Directions Shown

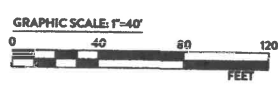
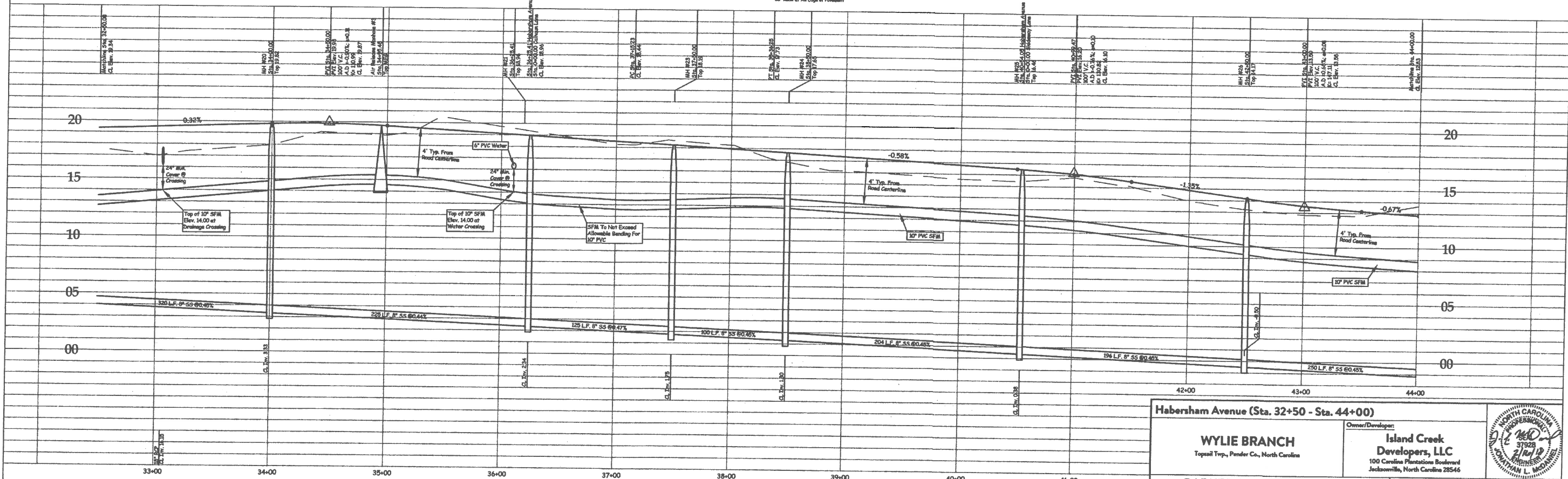

Habersham Avenue (Sta. 32+50 - Sta. 44+00)		
WYLIE BRANCH Topical Trwp., Pender Co., North Carolina	Island Creek Developers, LLC 100 Carolina Plantations Boulevard Jacksonville, North Carolina 28546	
PARKER & ASSOCIATES, INC. Consulting Engineers - Land Surveyors - Land Planners Jacksonville, North Carolina P.O. Box 976 - 28541-0976 306 New Bridge Street - 28540 Phone (910) 455-2414 - Fax (910) 455-3441 Firm License Number: F-0108		Sheet No. 18 of 34 Drawn: JLM Date: 06/16/17 Scale: Vertical 1"=40' Horizontal 1"=40' Filename: WB - Gen.dwg Date: 06/16/17 Job No.: S161130-4392

2:\wylie\civil\171118 At: Thru\DWG\WB - 18.dwg, 2/16/2018 8:36:54 AM, BLD

Rev. 02/16/18 BLD/171118 - Revises layout for ascor
 Rev. 10/11/17 BLD - Revises Lot Numbers
 Rev. 08/07/17 BLD - Revises For PAZ Review

Field Book: Wylie Branch, P-12



- Legend**
- BO - Blow Off
 - CL - Centerline
 - CD - Cal-de-sec
 - DI - Ductile Iron
 - Elev. - Elevation
 - EOP - Edge of Pavement
 - Ex. - Existing
 - FH - Fire Hydrant
 - GV - Gate Valve
 - Inv. - Invert
 - L - Length
 - MEP - Match Existing Grade
 - MH - Manhole
 - PC - Point of Curvature
 - PD - Positive Drainage
 - PL - Property Line
 - PT - Point of Tangency
 - P.T. - Flag Tagged
 - PVC - Polyvinyl Chloride
 - PVI - Point of Vertical Intersection
 - R - Radius
 - R/W - Right-of-way
 - RCP - Reinforced Concrete Pipe
 - Sta. - Station
 - s.t. - 10'x70' Sight Triangle
- T - Tangent (Typ) - Typical
 - Flow Arrow
 - Lot Number
 - Pipe Label
 - Proposed Spot Elevation
 - Stop Sign
 - Street Sign
 - Wetlands Hatch
 - Ditch or Swale
 - Existing Powerline
 - Silt Fence
 - Water Line
 - Wetlands Line

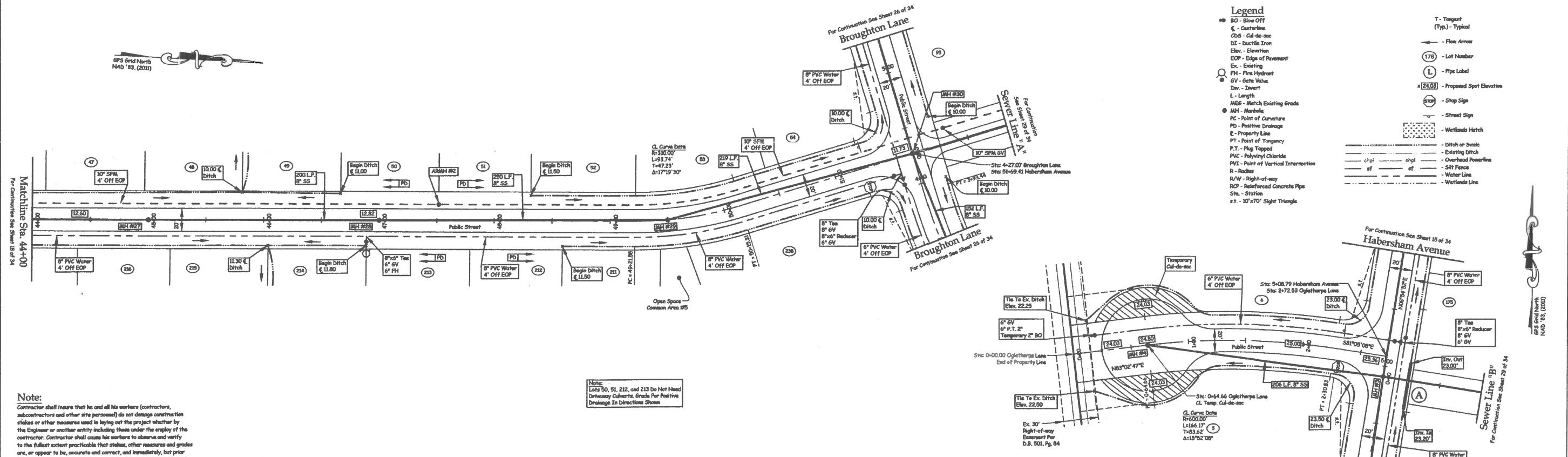

Note:
Contractor shall insure that he and all his workers (contractors, subcontractors and other site personnel) do not damage construction stakes or other measures used in laying out the project whether by the Engineer or another entity including those under the employ of the contractor. Contractor shall cause his workers to observe and verify to the fullest extent practicable that stakes, other measures and grades are, or appear to be, accurate and correct, and immediately, but prior to any associated work, notify the staking entity of any potential conflict, error or question regarding the work. The Engineer shall not be responsible if all of the above measures are not strictly adhered to. The Engineer shall not be responsible where due to damage, his staking can not be verified. For critical or costly components of the work, where the contractor believes that staking may not be preserved, the contractor shall request the staking entity to place staking in an area where its preservation can be insured.

Note:
Lots 50, 51, 212, and 213 do Not Need Driveway Culverts. Grade For Positive Drainage In Direction Shown

**Habersham Avenue
50' R/W**

Note:
At All Intersections:
20' Radii at All Rights-of-Way
30' Radii at All Edge of Pavement

**Oglethorpe Lane
50' R/W**

Note:
At All Intersections:
20' Radii at All Rights-of-Way
30' Radii at All Edge of Pavement

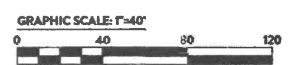
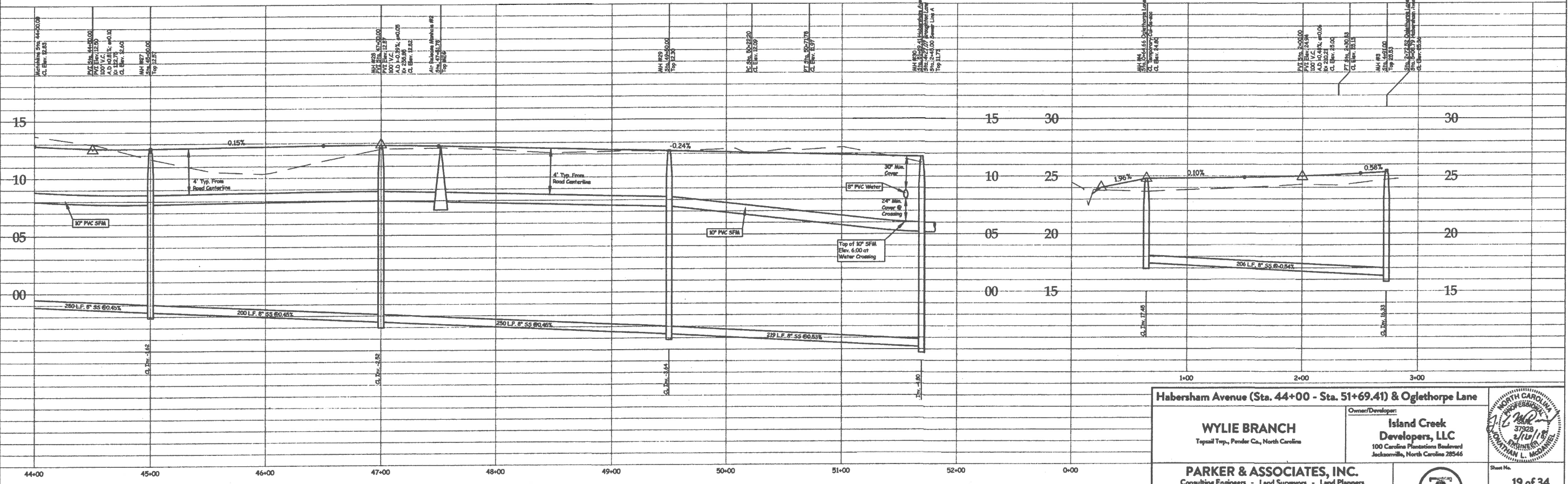

Rev. 02/16/18 BLD/EDW - Revised layout for sewer
Rev. 10/11/17 BLD - Label Blow-offs on Temporary or Permanent Per PCU Comments, Revise Lot Numbers
Rev. 06/07/17 BLD - Revised Per Septic Design and PAL Review

Field Book: Wylie Branch, Pg. 1-12

Habersham Avenue (Sta. 44+00 - Sta. 51+69.41) & Oglethorpe Lane		
WYLIE BRANCH Topical Top, Pender Co., North Carolina	Island Creek Developers, LLC 100 Carolina Plantations Boulevard Jacksonville, North Carolina 28546	
PARKER & ASSOCIATES, INC. Consulting Engineers - Land Surveyors - Land Planners Jacksonville, North Carolina P.O. Box 976 - 28541-0976 306 New Baldie Street - 28540 Phone (910) 455-2414 - Fax (910) 455-3441 Firm License Number: F-0108		Sheet No. 19 of 34 Drawn: JLM Check: BLD Date: 06/16/17 Scale: Vertical 1"=40' Horizontal 1"=40' Firm: WB - Gauley Dwg: Asst #2661 Job No.: 201700-0392

Z:\AutoCAD Civil 3D\2018 A4_Traffic\10461618 - Midway_2/16/2018 8:39:36 AM, BLD

For Continuation See Sheet 16 of 34

Habersham Avenue

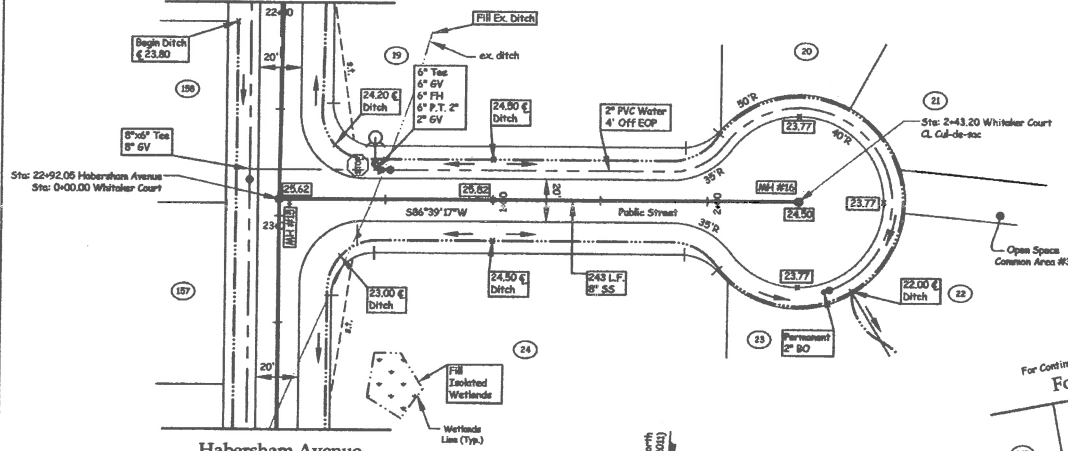

Habersham Avenue
For Continuation See Sheet 17 of 34

For Continuation See Sheet 21 of 34

Forsyth Lane

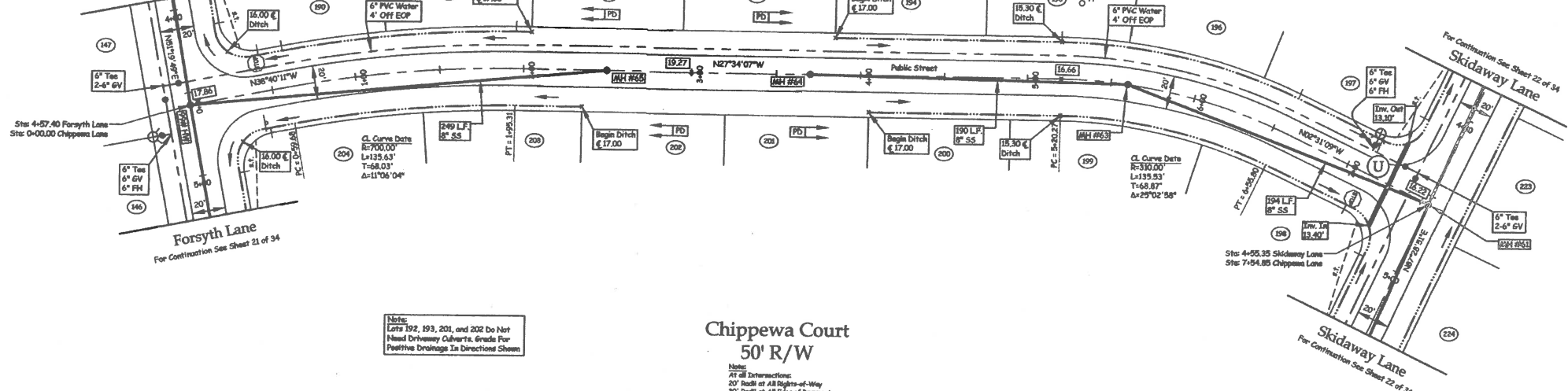

Forsyth Lane
For Continuation See Sheet 21 of 34

For Continuation See Sheet 22 of 34

Skidaway Lane

- Legend**
- BO - Blow Off
 - CL - Centerline
 - CDS - Cut-de-sec
 - Elev. - Elevation
 - EOP - Edge of Pavement
 - Exc. - Existing
 - FH - Fire Hydrant
 - GV - Gate Valve
 - Inv. - Invert
 - L - Length
 - MEG - Match Existing Grade
 - MH - Manhole
 - PC - Point of Curvature
 - PD - Positive Drainage
 - P - Property Line
 - PT - Point of Tangency
 - P.T. - Plug Topped
 - PVC - Polyvinyl Chloride
 - PVI - Point of Vertical Intersection
 - R - Radius
 - R/W - Right-of-way
 - RCP - Reinforced Concrete Pipe
 - Sta. - Station
 - 3\"/>

Note:
Contractor shall insure that he and all his workers (contractors, subcontractors and other site personnel) do not damage construction stakes or other measures used in laying out the project whether by the Engineer or another entity including those under the employ of the contractor. Contractor shall cause his workers to observe and verify to the fullest extent practicable that stakes, other measures and grades are, or appear to be, accurate and correct, and immediately, but prior to any associated work, notify the staking entity of any potential conflict, error or question regarding the work. The Engineer shall not be responsible if all of the above measures are not strictly adhered to. The Engineer shall not be responsible where due to damage, his staking can not be verified. For critical or costly components of the work, where the contractor believes that staking may not be preserved, the contractor shall request the staking entity to place staking in an area where its preservation can be insured.

Whitaker Court
50' R/W

Note:
At All Intersections:
20' Radii at All Right-of-Way
30' Radii at All Edges of Pavement

Note:
Lots 192, 193, 201, and 202 Do Not Need Driveway Culverts. Grade For Positive Drainage In Direction Shown

Chippewa Court
50' R/W

Note:
At All Intersections:
20' Radii at All Right-of-Way
30' Radii at All Edges of Pavement

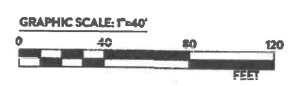
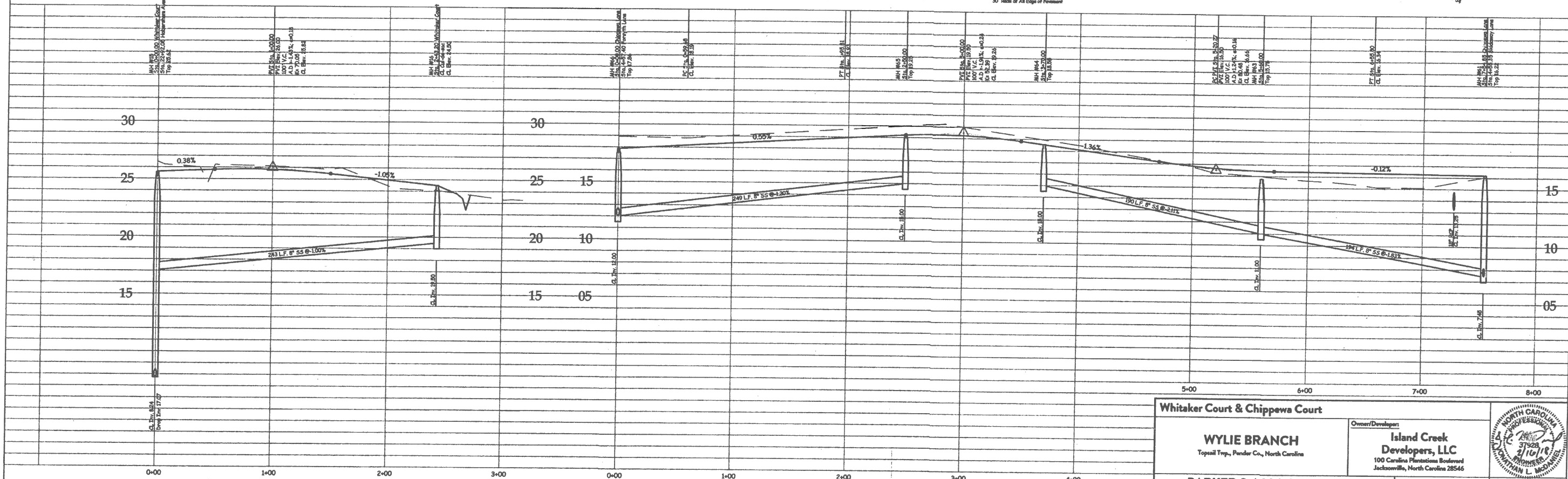

Whitaker Court & Chippewa Court		
WYLIE BRANCH Topical Twp., Pender Co., North Carolina	Island Creek Developers, LLC 100 Carolina Plantations Boulevard Jacksonville, North Carolina 28546	
PARKER & ASSOCIATES, INC. Consulting Engineers - Land Surveyors - Land Planners Jacksonville, North Carolina P.O. Box 976 - 28541-0976 306 New Bridge Street - 28540 Phone (910) 455-2414 - Fax (910) 455-3441 Firm License Number: F-0108		Sheet No. 20 of 34 Drawn: JLM Disc: BLD Job No: 561130-6392
Date: 06/06/17	Scale: Vertical 1"=40' Horizontal 1"=60'	Filmmat: WB - Geotag Disc: Amd #2661

Rev. 02/16/18 BLD/R/W - Revis layout for assessor
 Rev. 10/17/17 BLD - Lot/Blk blow-offs as Temporary or Permanent Per PCU Comments, Revise Lot Numbers
 Rev. 06/07/17 BLD - Revises Per Septic Design and P&E Review

Field Book: Wylie Branch, Pg. 1-12

Z:\unc\cd\ch\301218.A\Ther\DW\WB - hld.dwg, 2/10/2018 8:41:19 AM, BLD

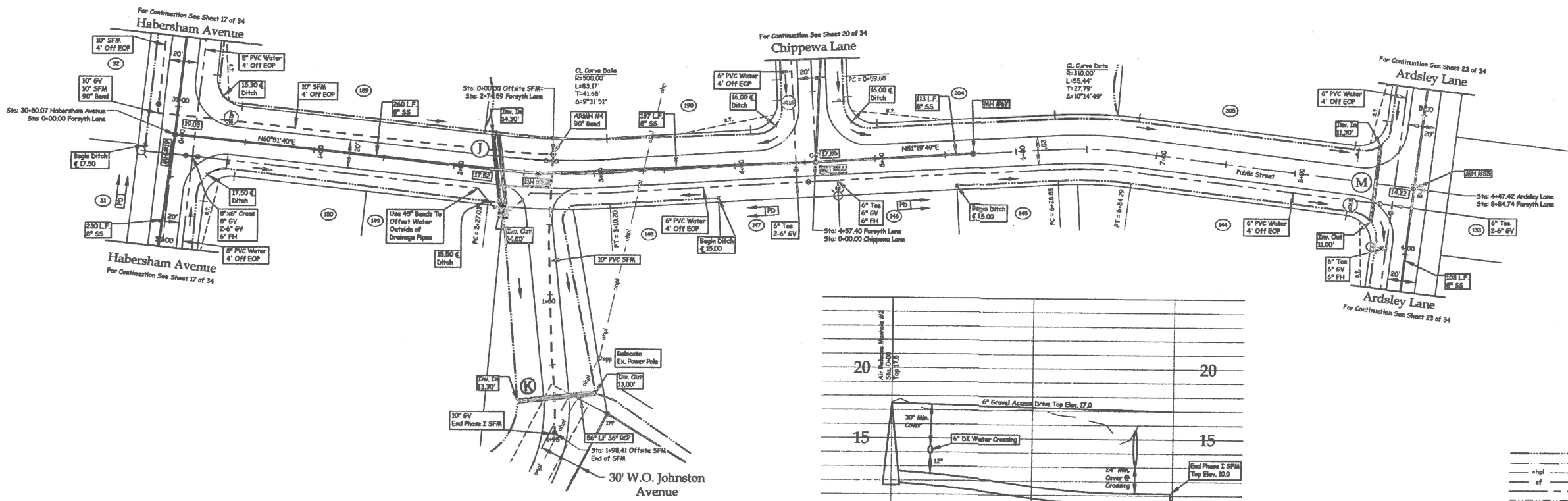

- Legend**
- 80 - Blow Off
 - ⊕ - Centerline
 - CD - Cleanout
 - DI - Ductile Iron Elev. - Elevation
 - EOP - Edge of Pavement
 - Ex - Existing
 - FH - Fire Hydrant
 - GV - Gate Valve
 - Inv. - Invert
 - L - Length
 - MSS - Match Existing Grade
 - NH - Manhole
 - PC - Point of Curvature
 - PD - Positive Drainage
 - P - Property Line
 - PT - Point of Tangency
 - P.T. - Flag Tapped
 - PVC - Polyvinyl Chloride
 - PVI - Point of Vertical Intersection
 - R - Radius
 - R/W - Right-of-way
 - RCP - Reinforced Concrete Pipe
 - Sta. - Station
 - s.t. - 10'x10' Sight Triangle
 - T - Tangent
 - (Typ.) - Typical
- Flow Arrow
 (170) - Lot Number
 L - Pipe Label
 → PD - Positive Drainage
 ±[24.03] - Proposed Spot Elevation
 (STOP) - Stop Sign
 Street Sign
 [Pattern] - Wetlands Hatch
 --- Ditch or Swale
 --- Existing Ditch
 --- Overhead Powerline
 --- Silt Fence
 --- Water Line
 --- Wetlands Line

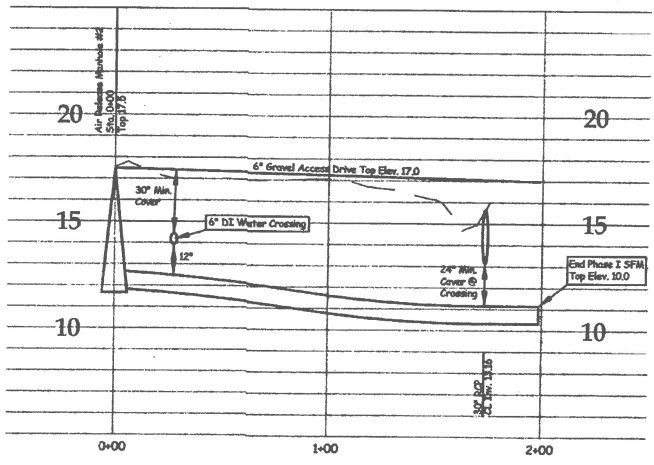

Offsite SFM

Note:
 Contractor shall insure that he and all his workers (contractors, subcontractors and other site personnel) do not damage construction stakes or other measures used in laying out the project whether by the Engineer or another entity including those under the employ of the contractor. Contractor shall cause his workers to observe and verify to the fullest extent practicable that stakes, other measures and grades are, or appear to be, accurate and correct, and immediately, but prior to any associated work, notify the staking entity of any potential conflict, error or question regarding the work. The Engineer shall not be responsible if all of the above measures are not strictly adhered to. The Engineer shall not be responsible where due to damage, his staking can not be verified. For critical or costly components of the work, where the contractor believes that staking may not be preserved, the contractor shall request the staking entity to place staking in an area where its preservation can be insured.

Note:
 Lots 146 and 147 Do Not Need Driveway Culverts. Grade For Positive Drainage To Direction Shown

**Forsyth Lane
 50' R/W**
Note:
 At All Intersections:
 20' Radius at All Rights-of-Way
 30' Radius at All Edge of Pavement

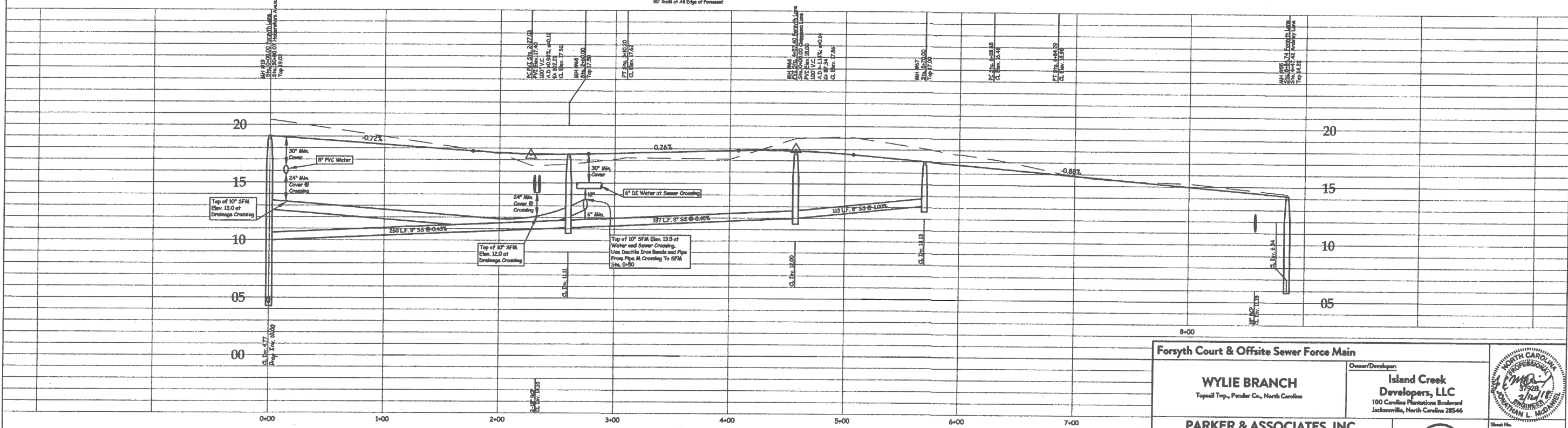

Rev. 02/16/18 BLD/7/1W - Revise layout for sewer
 Rev. 10/11/17 BLD - Label Blow-offs as Temporary or Permanent Per PCU Comments, Revise Lot Numbers, Add Street Calling For Gravity Sewer
 Rev. 06/07/17 BLD - Revise Per Geotech Design and P&E Review

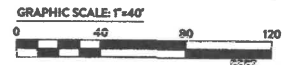

Forsyth Court & Offsite Sewer Force Main		
WYLIE BRANCH Topsoil Twp., Pender Co., North Carolina	Owner/Developer: Island Creek Developers, LLC 100 Carolina Plantations Boulevard Jacksonville, North Carolina 28546	
PARKER & ASSOCIATES, INC. Consulting Engineers - Land Surveyors - Land Planners Jacksonville, North Carolina P.O. Box 976 - 28541-0976 306 New Bridge Street - 28540 Phone (910) 455-2414 - Fax (910) 455-3441 Firm License Number: F-0108		Sheet No. 21 of 34 Designed: JLM Drawn: BLD
Date: 06/16/17	Scale: Vertical 1"=4' Horizontal 1"=40'	Planes: WB - Grounding Disk: Amd R2661 Job No.: 516130-692

Z:\InfoCAD\DWG\2018\Ac_Town\DWG\WB - 1.dwg, 2/16/2018 8:55:53 AM, BLD

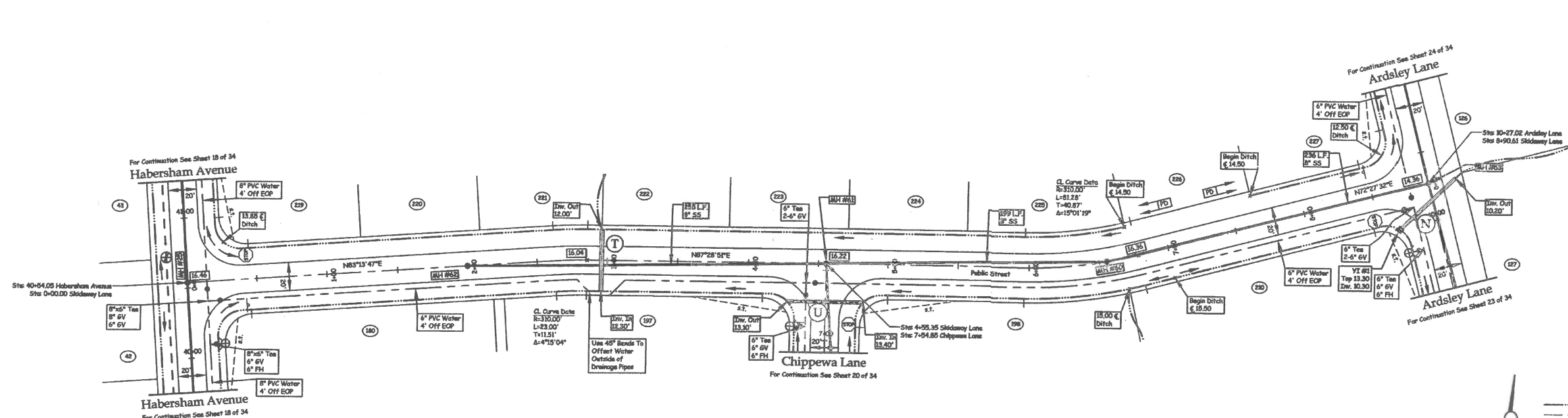

- Legend**
- BO - Blow Off
 - € - Centerline
 - CD5 - Cal-de-roc
 - Elev - Elevation
 - EOP - Edge of Pavement
 - Ex - Existing
 - FH - Fire Hydrant
 - GV - Gate Valve
 - In - Invert
 - L - Length
 - MEG - Match Existing Grade
 - PC - Point of Curvature
 - PD - Positive Drainage
 - PL - Property Line
 - PT - Point of Tangency
 - PT - Plus Tapped
 - PVC - Polyvinyl Chloride
 - PVI - Point of Vertical Intersection
 - R - Radius
 - R/W - Right-of-way
 - RCF - Reinforced Concrete Pipe
 - Sta. - Station
 - s.t. - 30'x70' Sight Triangle
 - T - Tangent
 - (Typ.) - Typical
- Flow Arrow
- (170) - Lot Number
- L - Pipe Label
- PD - Positive Drainage
- x(24.03) - Proposed Spot Elevation
- STOP - Stop Sign
- Street Sign
- Workforce Hatch
- Ditch or Swale
- Existing Ditch
- Overhead Powerline
- Station
- Water Line
- Workforce Line

Note:
 Contractor shall insure that he and all his workers (contractors, subcontractors and other site persons) do not damage construction stakes or other markers used in laying out the project whether by the Engineer or another entity including those under the employ of the contractor. Contractor shall cause his workers to observe and verify to the fullest extent practicable that stakes, other markers and grades are, or appear to be, accurate and correct, and immediately, but prior to any associated work, notify the staging entity of any potential conflict, error or question regarding this work. The Engineer shall not be responsible if all of the above measures are not strictly adhered to. The Engineer shall not be responsible where due to damage, his staging can not be verified. For critical or costly components of the work, where the contractor believes that staging may not be preserved, the contractor shall request the staging entity to place staging in an area where its preservation can be insured.

**Skidaway Lane
 50' R/W**

Note:
 Lot 226 Does Not Need Driveway Culverts. Grade For Positive Drainage In Direction Shown

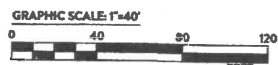
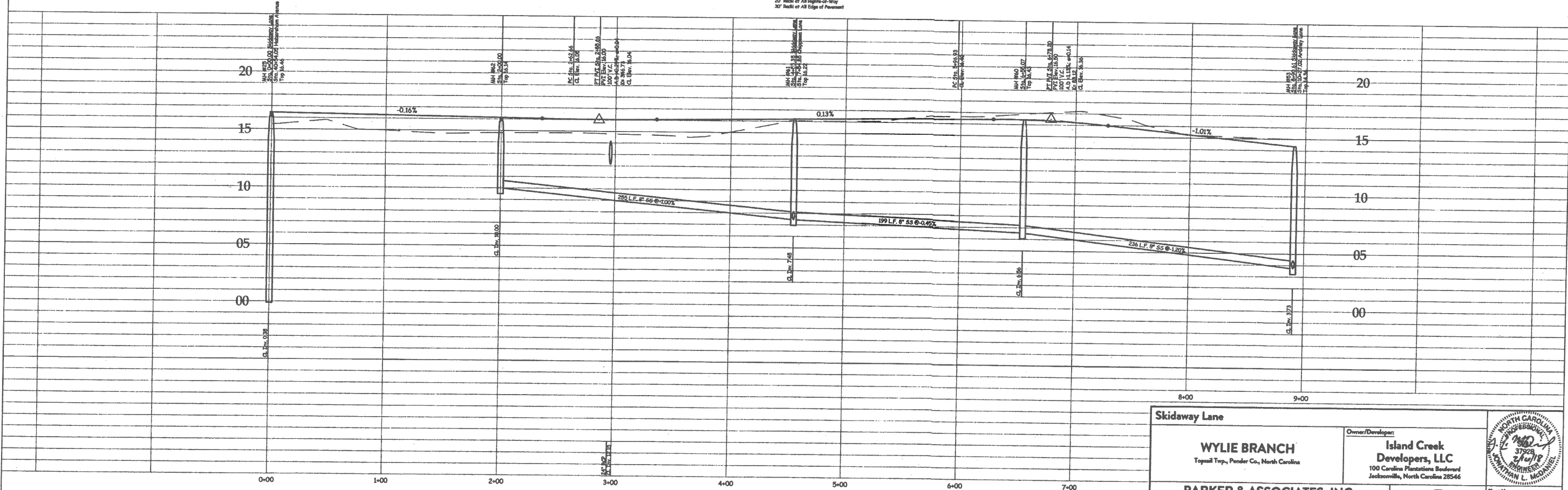

Rev. 02/16/18 BLD/IS/W - Revise layout for owner
 Rev. 10/11/17 BLD - Label Blow-offs as Temporary or Permanent Per PCU Comments, Revise Lot Numbers
 Rev. 06/07/17 BLD - Revise Per PAI Review

Skidaway Lane		
WYLIE BRANCH Topsoil Trng., Pender Co., North Carolina		
Owner/Developer: Island Creek Developers, LLC 100 Carolina Plantations Boulevard Jacksonville, North Carolina 28546		Sheet No. 22 of 34
PARKER & ASSOCIATES, INC. Consulting Engineers - Land Surveyors - Land Planners Jacksonville, North Carolina P.O. Box 976 - 28541-0976 306 New Bridge Street - 28540 Phone (910) 455-2414 - Fax (910) 455-3441 Firm License Number: F-0106		
Date: 06/16/17	Scale: Vertical 1"=40' Horizontal 1"=40'	Drawn: JLM Checked: BLD Job No.: S16130-6392

Z:\InfoCAD\DWG\13\2128 At Thru\13\DWG\WB - 16d.dwg, 2/16/2018 8:56:25 AM, BLD



For Continuation See Sheet 23 of 34
Matchline Sta. 11+00

For Continuation See Sheet 22 of 34
Matchline Sta. 22+00

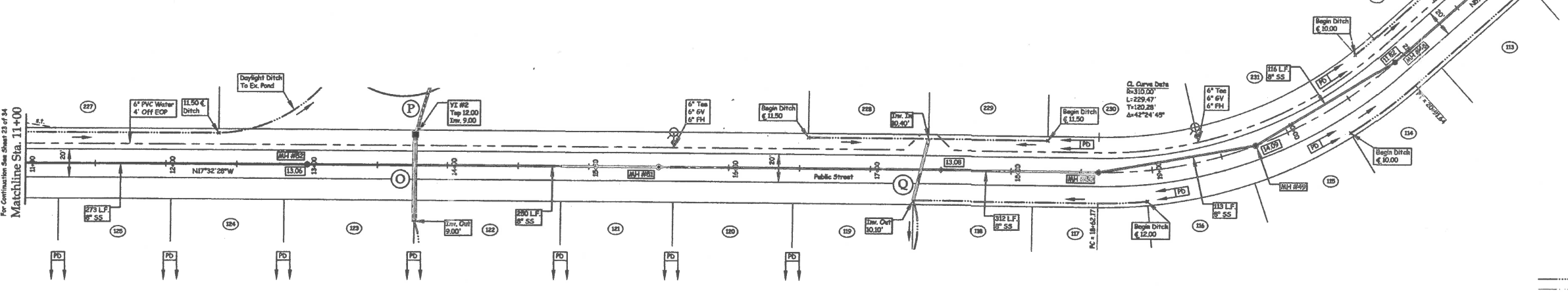

- Legend**
- ⊙ - Slope Off
 - ⊙ - Centerline
 - CD - Call-de-acc
 - Elev. - Elevation
 - EOP - Edge of Pavement
 - Ex. - Existing
 - FH - Fire Hydrant
 - GV - Gate Valve
 - In. - Invert
 - L - Length
 - MEG - Match Existing Grade
 - PC - Point of Curvature
 - PD - Positive Drainage
 - P - Property Line
 - PT - Point of Tangency
 - P.T. - Plug Topped
 - PVC - Polyvinyl Chloride
 - PVI - Point of Vertical Intersection
 - R - Radius
 - R/W - Right-of-way
 - RCP - Reinforced Concrete Pipe
 - Sta. - Station
 - s.t. - 10'x70' Sight Triangle
 - T - Tangent
 - (Typ.) - Typical
 - - Flow Arrow
 - (176) - Lot Number
 - (L) - Pipe Label
 - x24.03 - Proposed Spot Elevation
 - ⊙ - Stop Sign
 - ⊙ - Street Sign
 - ▨ - Wetlands Hatch
 - - - - - Ditch or Smale
 - - - - - Existing Ditch
 - - - - - Overhead Powerline
 - - - - - Silty Fence
 - - - - - Water Line
 - - - - - Wetlands Line

Note:
Contractor shall insure that he and all his workers (contractors, subcontractors and other site personnel) do not damage construction stakes or other measures used in laying out the project whether by the Engineer or another entity including those under the employ of the contractor. Contractor shall cause his workers to observe and verify to the fullest extent practicable that stakes, other measures and grades are, or appear to be, accurate and correct, and immediately, but prior to any associated work, notify the staking entity of any potential conflict, error or question regarding the work. The Engineer shall not be responsible if all of the above measures are not strictly adhered to. The Engineer shall not be responsible where due to damage, his staking can not be verified. For critical or costly components of the work, where the contractor believes that staking may not be preserved, the contractor shall request the staking entity to place staking in an area where its preservation can be insured.

Note:
No roadside ditch on the east side of Ardsley Lane from lot 125 to 134. Each lot to be filled and graded for positive drainage between each lot with no driveway culvert.

**Ardsley Lane
50' R/W**

At all Intersections:
20' Back of All Right-of-Way
30' Back of All Edge of Pavement

Note:
Lots 115, 116, 230 and 231
Do Not Place Driveway Culverts.
Grade For Positive Drainage In
Directions Shown

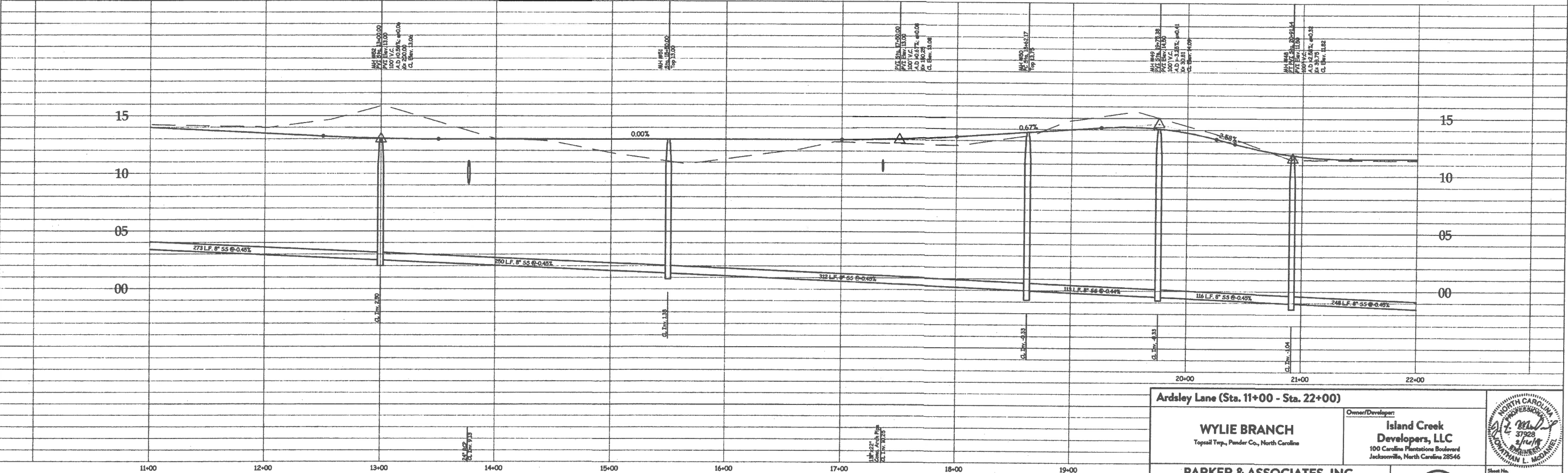

Rev. 02/16/18 BLD/10-W - Revises layout for owner
Rev. 10/11/17 BLD - Revises Lot Numbers
Rev. 08/07/17 BLD - Revises Per-PAGE Review

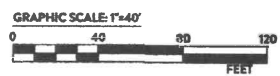

Field Book: Wylie Branch, Pg. 1-12

Ardsley Lane (Sta. 11+00 - Sta. 22+00)		
WYLIE BRANCH Topsail Trp., Pender Co., North Carolina	Owner/Developer: Island Creek Developers, LLC 100 Carolina Plantations Boulevard Jacksonville, North Carolina 28546	
PARKER & ASSOCIATES, INC. Consulting Engineers - Land Surveyors - Land Planners Jacksonville, North Carolina P.O. Box 976 - 28541-0976 306 New Bridge Street - 28540 Phone (910) 455-2414 - Fax (910) 455-3441 Firm License Number: F-0108		
Date: 06/16/17	Scale: Vertical 1"=4' Horizontal 1"=40'	Drawn: WB - Gauding
Sheet No. 24 of 34	Design: JRM	Job No: S16130-4892

Note:
 Contractor shall insure that he and all his workers (contractors, subcontractors and other site personnel) do not damage construction stakes or other measures used in laying out the project whether by the Engineer or another entity including those under the employ of the contractor. Contractor shall cause his workers to observe and verify to the fullest extent practicable that stakes, other measures and grades are, or appear to be, accurate and correct, and immediately, but prior to any associated work, notify the staking entity of any potential conflict, error or question regarding the work. The Engineer shall not be responsible if all of the above measures are not strictly adhered to. The Engineer shall not be responsible where due to damage, his staking can not be verified. For critical or costly components of the work, where the contractor believes that staking may not be preserved, the contractor shall request the staking entity to place staking in an area where its preservation can be insured.

Legend

- BO - Blow Off
- € - Centerline
- CLS - Cul-de-sac
- Elev. - Elevation
- EOP - Edge of Pavement
- Ex. - Existing
- FH - Fire Hydrant
- GV - Gate Valve
- Inv. - Invert
- L - Length
- MES - Match Existing Grade
- PC - Point of Curvature
- PD - Positive Drainage
- P - Property Line
- PT - Point of Tangency
- P.T. - Plug Tapped
- PVC - Polyvinyl Chloride
- PVI - Point of Vertical Intersection
- R - Radius
- R/W - Right-of-way
- RCP - Reinforced Concrete Pipe
- Sta. - Station
- s.t. - 10'x70' Sight Triangle
- T - Tangent
- (Typ.) - Typical

- Flow Arrow
- (178) - Lot Number
- (L) - Pipe Label
- 24.03 - Proposed Spot Elevation
- (STOP) - Stop Sign
- (S) - Street Sign

- Wetlands Hatch
- Ditch or Swale
- Existing Ditch
- Overhead Powerline
- Water Line
- Wetlands Line

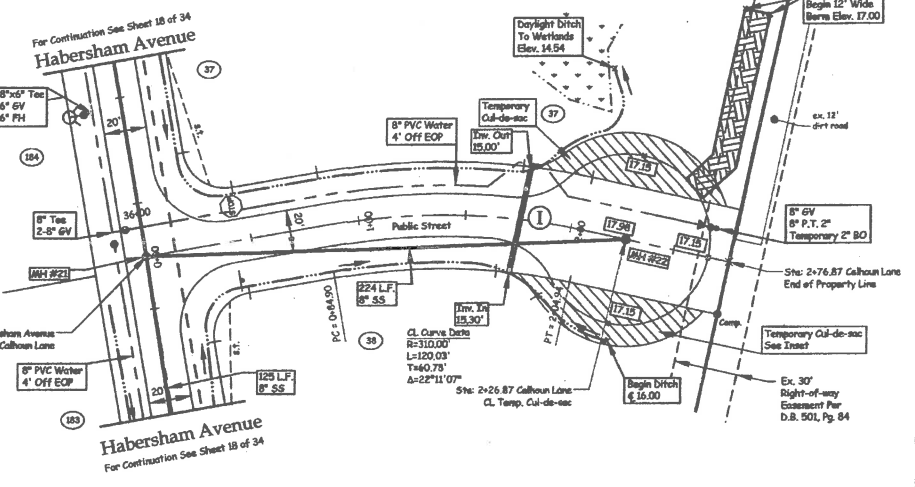
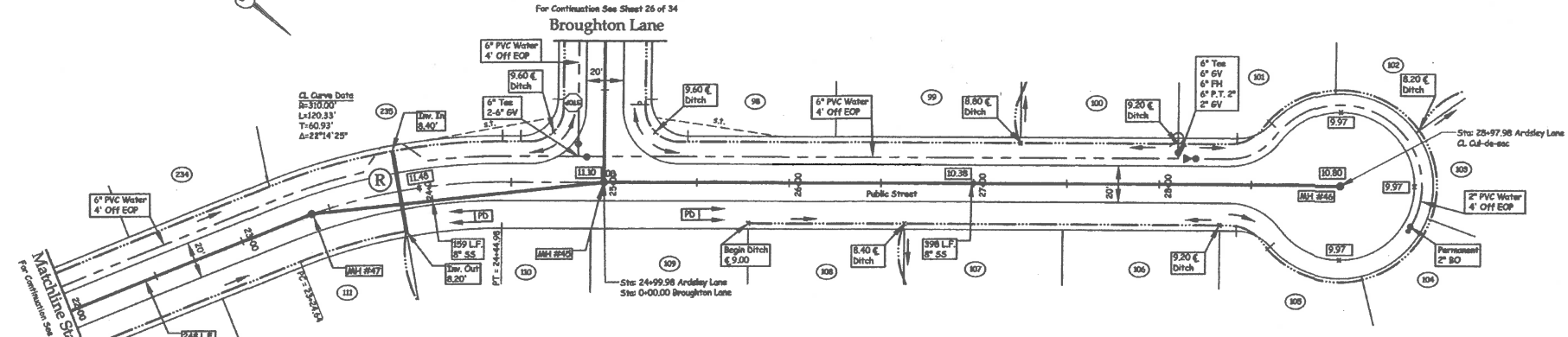
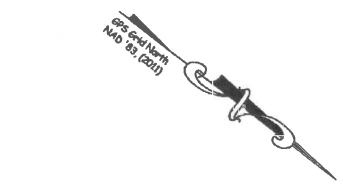

Ardsley Lane
 50' R/W

Note:
 Lot 49 Does Not Need a Driveway
 Culvert. Grade For Positive
 Drainage In Direction Shown

Calhoun Lane
 50' R/W

Note:
 At All Intersections:
 20' Radii at All Rights-of-Way
 30' Radii at All Edges of Pavement

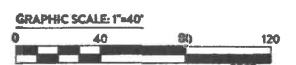
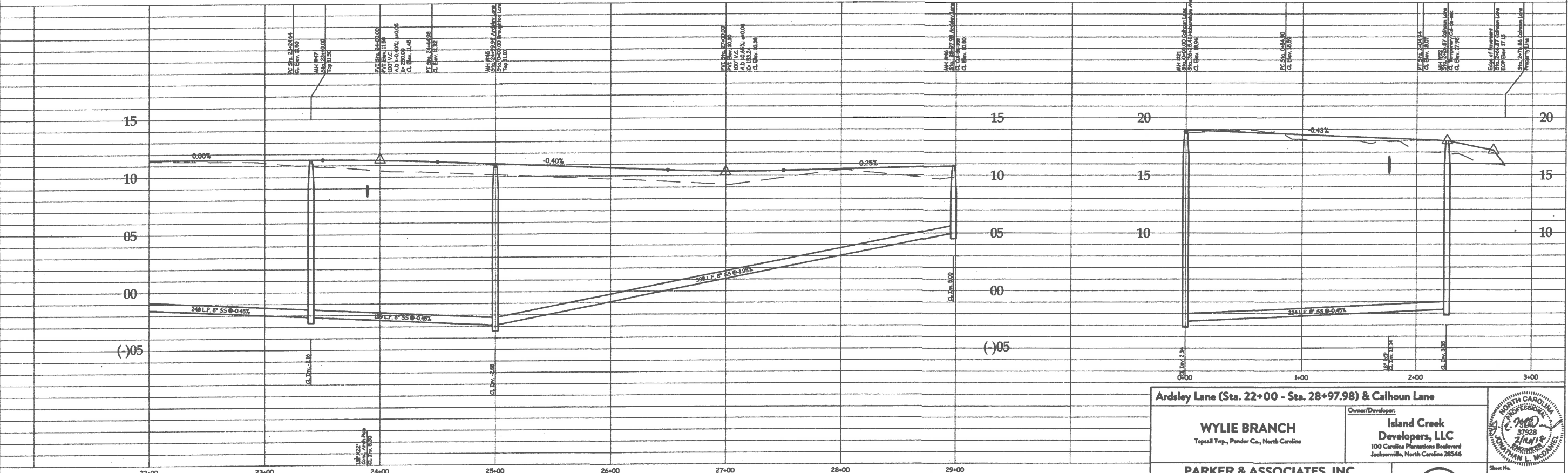

Rev. 02/16/15 BLD/PAW - Revised layout for owner
 Rev. 03/11/17 BLD - Revised Lot Numbers
 Rev. 06/07/17 BLD - Revised Pipe PAV Revision

Field Book: Wylie Branch, Pg. 1-12

Ardsley Lane (Sta. 22+00 - Sta. 28+97.98) & Calhoun Lane		
WYLIE BRANCH Topsoil Trp., Pender Co., North Carolina	Owner/Developer: Island Creek Developers, LLC 100 Carolina Plantations Boulevard Jacksonville, North Carolina 28546	
PARKER & ASSOCIATES, INC. Consulting Engineers - Land Surveyors - Land Planners Jacksonville, North Carolina P.O. Box 976 - 28544-0976 306 New Bridge Street - 28540 Phone (910) 455-2414 - Fax (910) 455-3441 Firm License Number: F-0108		Sheet No. 25 of 34 Designer: JLM Drafter: BLD Date: 06/16/17 Scale: Vertical F=4 Horizontal F=40 Filmmaker: WB - Gen. Eng. Disk: Acad #2608 Job No.: 581130-6392

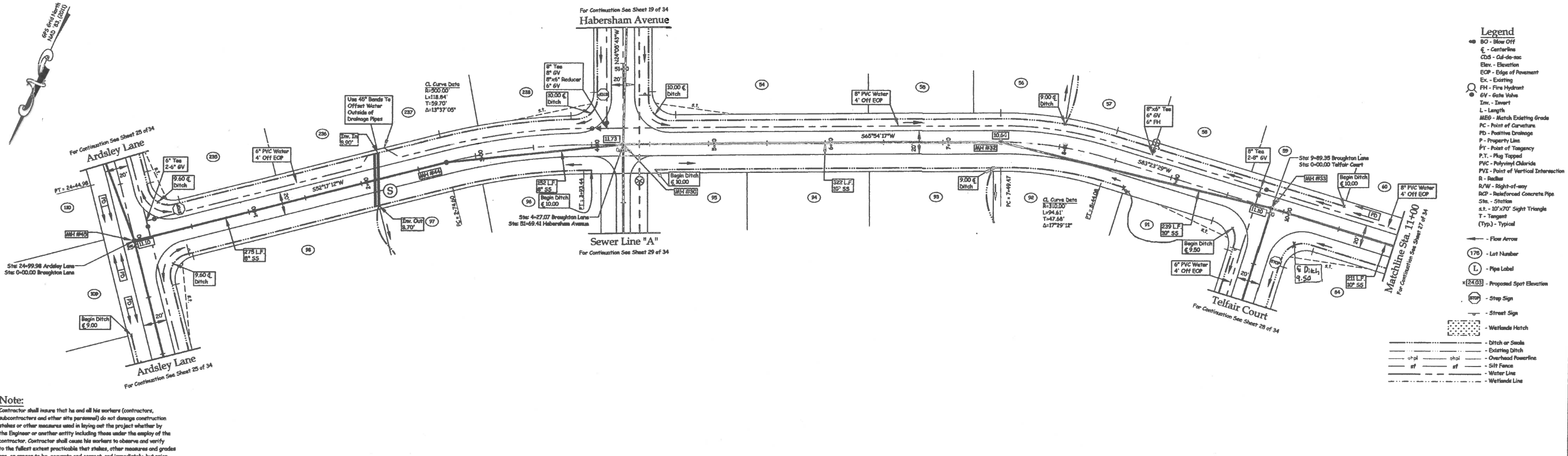

- Legend**
- BO - Blow Off
 - C - Centerline
 - CD - Cal-de-roc
 - Elev. - Elevation
 - EOP - Edge of Pavement
 - Ex. - Existing
 - FH - Fire Hydrant
 - GV - Gate Valve
 - In. - Invert
 - L - Length
 - MEG - Match Existing Grade
 - PC - Point of Curvature
 - PD - Positive Drainage
 - P - Property Line
 - PT - Point of Tangency
 - P.T. - Plug Tapped
 - PVC - Polyvinyl Chloride
 - PVI - Point of Vertical Intersection
 - R - Radius
 - R/W - Right-of-way
 - RCP - Reinforced Concrete Pipe
 - Sta. - Station
 - s.t. - 10'x70' Sight Triangle
 - T - Tangent (Typ.) - Typical
- - Flow Arrow
 - (176) - Lot Number
 - L - Pipe Label
 - 24.03 - Proposed Spot Elevation
 - Stop Sign
 - Street Sign
 - Wetlands Hatch
 - Ditch or Swale
 - Existing Ditch
 - Overhead Powerline
 - Silt Fence
 - Water Line
 - Wetlands Line

Note:
 Contractor shall insure that he and all his workers (contractors, subcontractors and other site personnel) do not damage construction stakes or other measures used in laying out the project whether by the Engineer or another entity including those under the employ of the contractor. Contractor shall cause his workers to observe and verify to the fullest extent practicable that stakes, other measures and grades are, or appear to be, accurate and correct, and immediately, but prior to any associated work, notify the staking entity of any potential conflict, error or question regarding the work. The Engineer shall not be responsible if all of the above measures are not strictly adhered to. The Engineer shall not be responsible where due to damage, his staking is not verified. For critical or costly components of the work, where the contractor believes that staking may not be preserved, the contractor shall request the staking entity to place staking in an area where its preservation can be insured.

**Broughton Lane
 50' R/W**

Note:
 Lot 109 and 110 Does Not Need a Driveway Culvert. Grade For Positive Drainage In Direction Shown

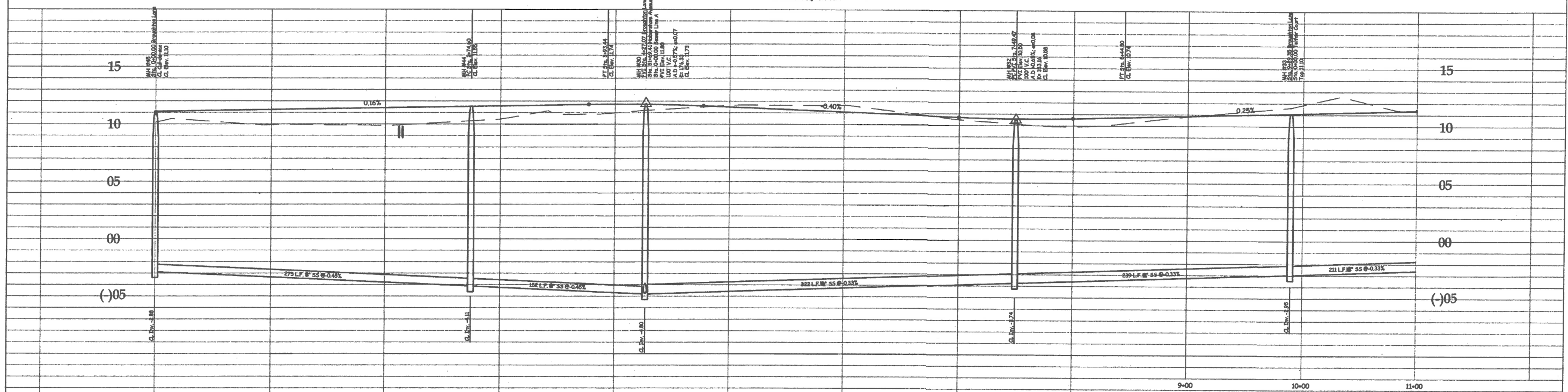

Rev. 02/16/18 BLD/RSW - Review layout for meter
 Rev. 10/11/17 BLD - Review Lot Numbers
 Rev. 06/07/17 BLD - Review Per PAT Review

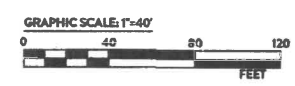

Field Book: Wylie Branch, Pg. 1-2

Broughton Lane (Sta. 00+00 - Sta. 11+00)		
WYLIE BRANCH Topwell Twp., Pender Co., North Carolina	Owner/Developer: Island Creek Developers, LLC 100 Carolina Plantations Boulevard Jacksonville, North Carolina 28546	
PARKER & ASSOCIATES, INC. Consulting Engineers - Land Surveyors - Land Planners Jacksonville, North Carolina P.O. Box 976 - 28541-0976 306 New Bridge Street - 28540 Phone (910) 455-2414 - Fax (910) 455-3441 Firm License Number: F-0108		
Date: 06/16/17	Scale: Vertical Feet Horizontal 1"=40'	Filename: WB - Gen.dwg
Sheet No. 26 of 34	Design: JLM	Drawn: BLD
Job No.: S16130-0392		

Z:\MFC\0 Civil 3D\218 As: Twp\DWG\WB - Bld.dwg, 2/16/2018 9:18:54 AM, BLD

Note:
Contractor shall insure that he and all his workers (contractors, subcontractors and other site personnel) do not damage construction stakes or other measures used in laying out this project whether by the Engineer or another entity including those under the employ of the contractor. Contractor shall cause his workers to observe and verify to the fullest extent practicable that stakes, other measures and grades are, or appear to be, accurate and correct, and immediately, but prior to any associated work, notify the staking entity of any potential conflict, error or question regarding the work. The Engineer shall not be responsible if all of the above measures are not strictly adhered to. The Engineer shall not be responsible where due to damage, his staking can not be verified. For critical or costly components of the work, where the contractor believes that staking may not be preserved, the contractor shall request the staking entity to place staking in an area where its preservation can be insured.

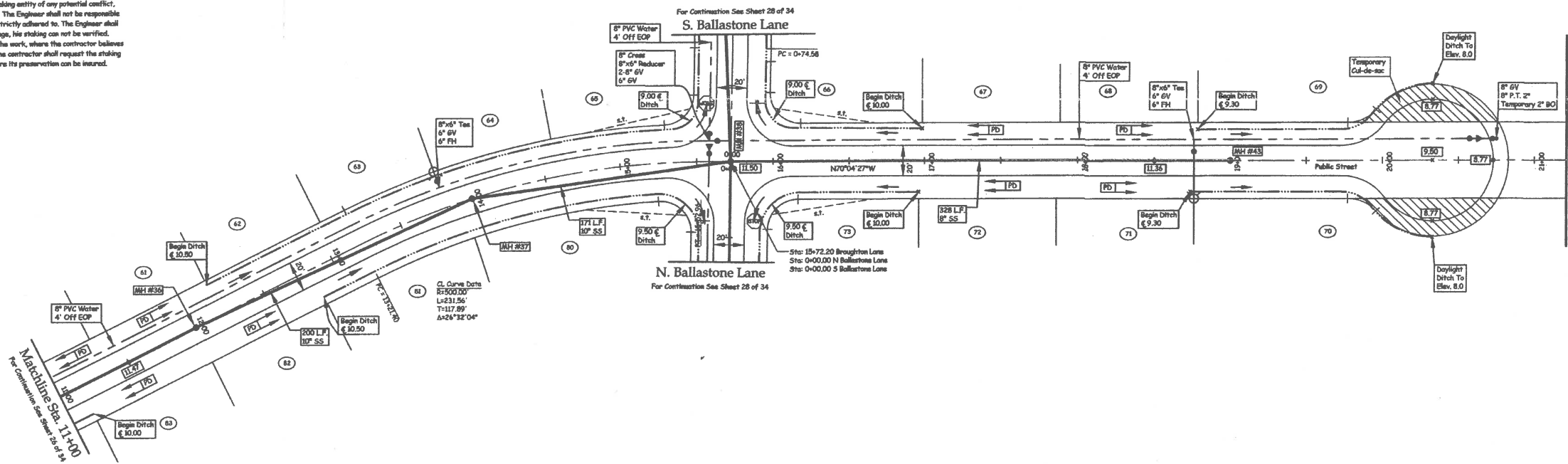

- Legend**
- BO - Blow Off
 - CL - Centerline
 - CDS - Cut-de-sac
 - Elev. - Elevation
 - EOP - Edge of Pavement
 - Exc. - Existing
 - FH - Fire Hydrant
 - GV - Gate Valve
 - Inv. - Invert
 - L - Length
 - MES - Match Existing Grade
 - PC - Point of Curvature
 - PD - Positive Drainage
 - P - Property Line
 - PT - Point of Tangency
 - P.T. - Plug Topped
 - PVC - Polyvinyl Chloride
 - PVI - Point of Vertical Intersection
 - R - Radius
 - R/W - Right-of-way
 - RCP - Reinforced Concrete Pipe
 - Sta. - Station
 - s.t. - 30'x70' Sight Triangle
 - T - Tangent
 - (Typ.) - Typical
 - - Flow Arrow
 - (176) - Lot Number
 - (L) - Pipe Label
 - (9.30) - Proposed Spot Elevation
 - (Stop) - Stop Sign
 - (Street Sign) - Street Sign
 - (Wetlands Match) - Wetlands Match
 - (Ditch or Swale) - Ditch or Swale
 - (Existing Ditch) - Existing Ditch
 - (ohs) - Overhead Powerline
 - (sf) - Silt Fence
 - (Wetline) - Wetline
 - (Wetlands Line) - Wetlands Line

**Broughton Lane
50' R/W**

Note:
Lots 60, 61, 67, 68, 71, 72, and 83 do not need driveway Culverts. Grade for Positive Drainage in Direction Shown.

Note:
At all Intersections:
20' Radii at All Right-of-Way
30' Radii at All Edge of Pavement

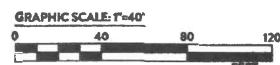
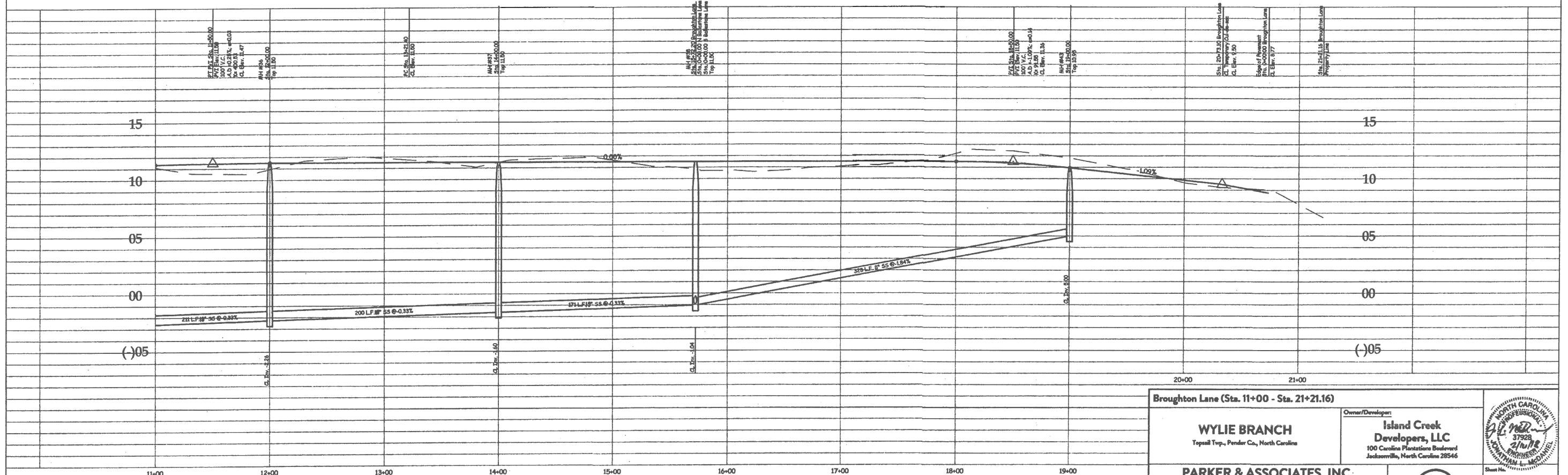

Field Book: Wylie Branch, Pg. 1-12

Broughton Lane (Sta. 11+00 - Sta. 21+21.16)		WYLIE BRANCH Troyall Twp., Pender Co., North Carolina		Island Creek Developers, LLC 100 Carolina Plantations Boulevard Jacksonville, North Carolina 28546	
PARKER & ASSOCIATES, INC. Consulting Engineers - Land Surveyors - Land Planners P.O. Box 976 - 28541-0976 306 New Bridge Street - 28540 Phone (910) 455-2414 - Fax (910) 455-3441 Firm License Number: F-0108				Sheet No. 27 of 34 Drawn: JLM Check: BLD	
Date: 06/16/17	Scale: Vertical 1"=40' Horizontal 1"=40'	Prepared: WB - Gauding	Disc: Amd #2661	Job No: SH1130-0392	

Rev: 02/16/18 BLD/10/17 - Revises layout for owner
 Rev: 10/11/17 BLD - Label Blow-offs as Temporary or Permanent Per PCU Comments, Revises Lot Numbers
 Rev: 06/07/17 BLD - Revises Per Septic Design and PAT Review

Note:
Contractor shall insure that he and all his workers (contractors, subcontractors and other site personnel) do not damage construction stakes or other markers used in laying out the project whether by the Engineer or another entity including those under the employ of the contractor. Contractor shall cause his workers to observe and verify to the fullest extent practicable that stakes, other measures and grades are, or appear to be, accurate and correct, and immediately, but prior to any associated work, notify the staking entity of any potential conflict, error or question regarding the work. The Engineer shall not be responsible if all of the above measures are not strictly adhered to. The Engineer shall not be responsible where due to damage, the staking can not be verified. For critical or costly components of the work, where the contractor believes that staking may not be preserved, the contractor shall request the staking entity to place staking in an area where its preservation can be insured.

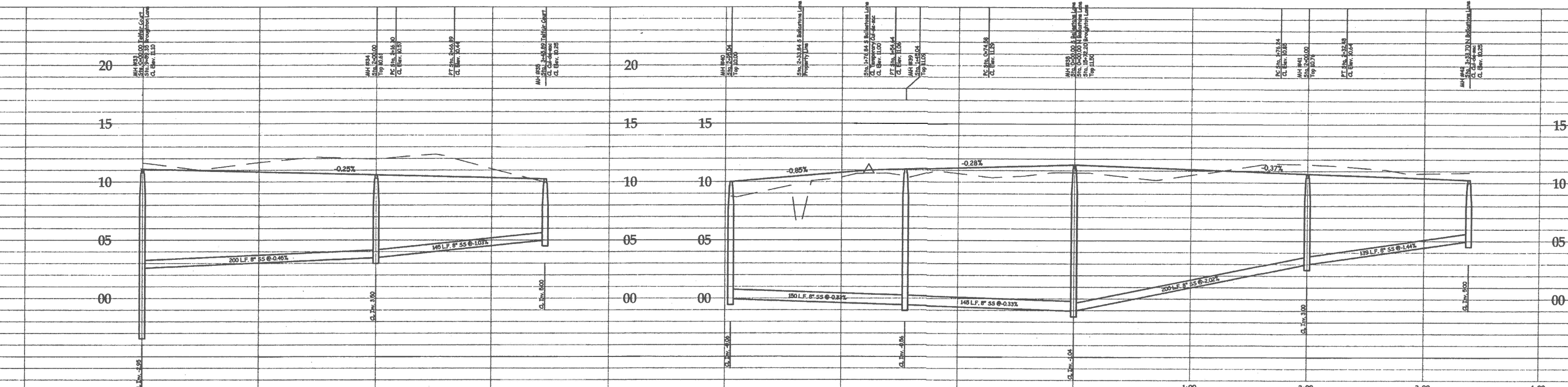
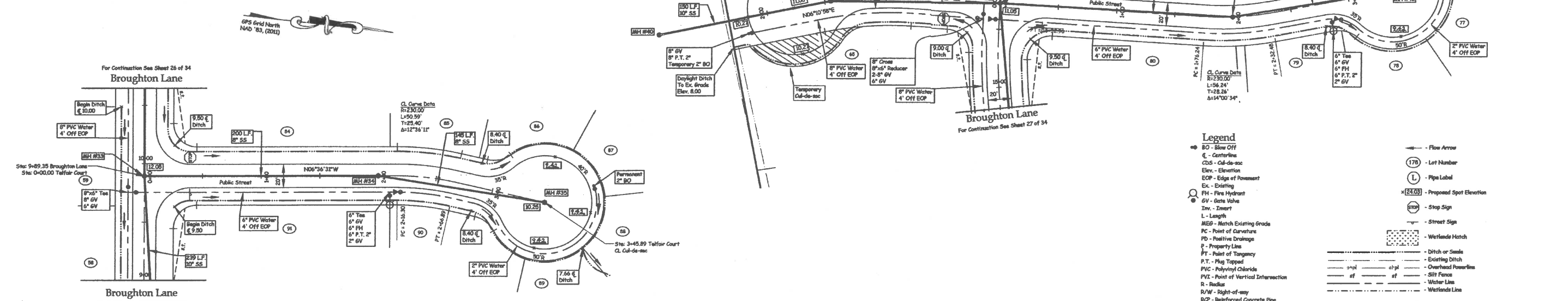

<p>Telfair Court & Ballastone Lane</p> <p>WYLIE BRANCH Topical Trp., Pender Co., North Carolina</p>		<p>Owner/Developer: Island Creek Developers, LLC 100 Carolina Plantations Boulevard Jacksonville, North Carolina 28546</p>		
<p>PARKER & ASSOCIATES, INC. Consulting Engineers - Land Surveyors - Land Planners Jacksonville, North Carolina P.O. Box 976 - 28541-0976 306 New Bridge Street - 28540 Phone (910) 455-2414 - Fax (910) 455-3441 Firm License Number: F-0108</p>		<p>Sheet No. 28 of 34</p> <p>Design: JLM Drawn: BLD Date: 06/16/17 Scale: Vertical 1"=40' Horizontal 1"=40' Filename: WB - Ganding Dial: Amd #2661 Job No.: S06130-6992</p>		

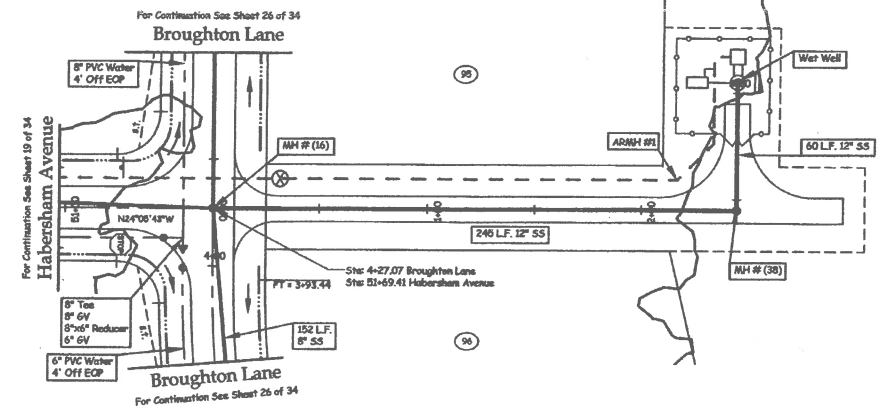
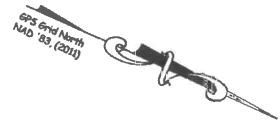

- Legend**
- BO - Blow Off
 - C - Catch Basin
 - CD - Cal-de-roc
 - Elev. - Elevation
 - EOP - Edge of Pavement
 - Ex. - Existing
 - FH - Fire Hydrant
 - GV - Gate Valve
 - Inv. - Invert
 - L - Length
 - MES - Match Existing Grade
 - PC - Point of Curvature
 - PD - Positive Drainage
 - P - Property Line
 - PT - Point of Tangency
 - P.T. - Flag Tapped
 - PVC - Polyvinyl Chloride
 - PVI - Point of Vertical Intersection
 - R - Radius
 - R/W - Right-of-way
 - RCP - Reinforced Concrete Pipe
 - Sta. - Station
 - s.t. - 30'x70' Sight Triangle
 - T - Tangent
 - (Typ.) - Typical
- Flow Arrow
 - 170 - Lot Number
 - L - Pipe Label
 - 24.03 - Proposed Spot Elevation
 - Stop Sign
 - Street Sign
 - Wetlands Hatch
 - Ditch or Swale
 - Existing Ditch
 - Overhead Powerline
 - Wetlands Line

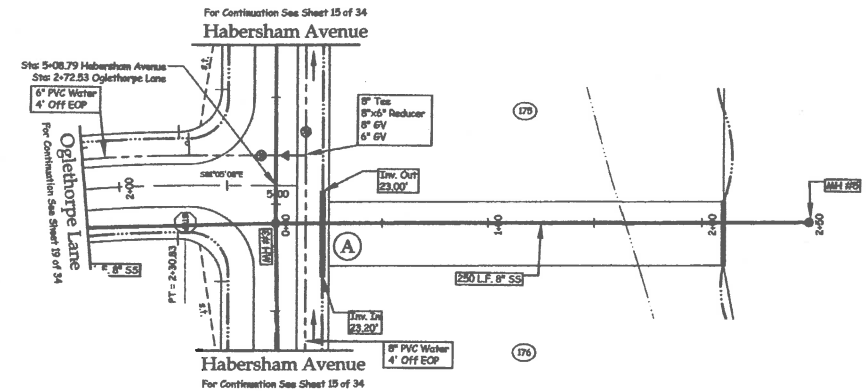

Note:
Contractor shall insure that he and all his workers (contractors, subcontractors and other site personnel) do not damage construction stakes or other measures used in laying out the project whether by the Engineer or another entity including those under the employ of the contractor. Contractor shall cause his workers to observe and verify to the fullest extent practicable that stakes, other measures and grades are, or appear to be, accurate and correct, and immediately, but prior to any associated work, notify the staking entity of any potential conflict, error or question regarding the work. The Engineer shall not be responsible if all of the above measures are not strictly adhered to. The Engineer shall not be responsible where due to damage, his staking can not be verified. For critical or costly components of the work, where the contractor believes that staking may not be preserved, the contractor shall request the staking entity to place staking in an area where its preservation can be insured.

Sewer Line "A"

Note:
At all Intersections:
20' Radii at All Right-of-Way
30' Radii at All Edge of Pavement

Sewer Line "B"

Note:
At all Intersections:
20' Radii at All Right-of-Way
30' Radii at All Edge of Pavement

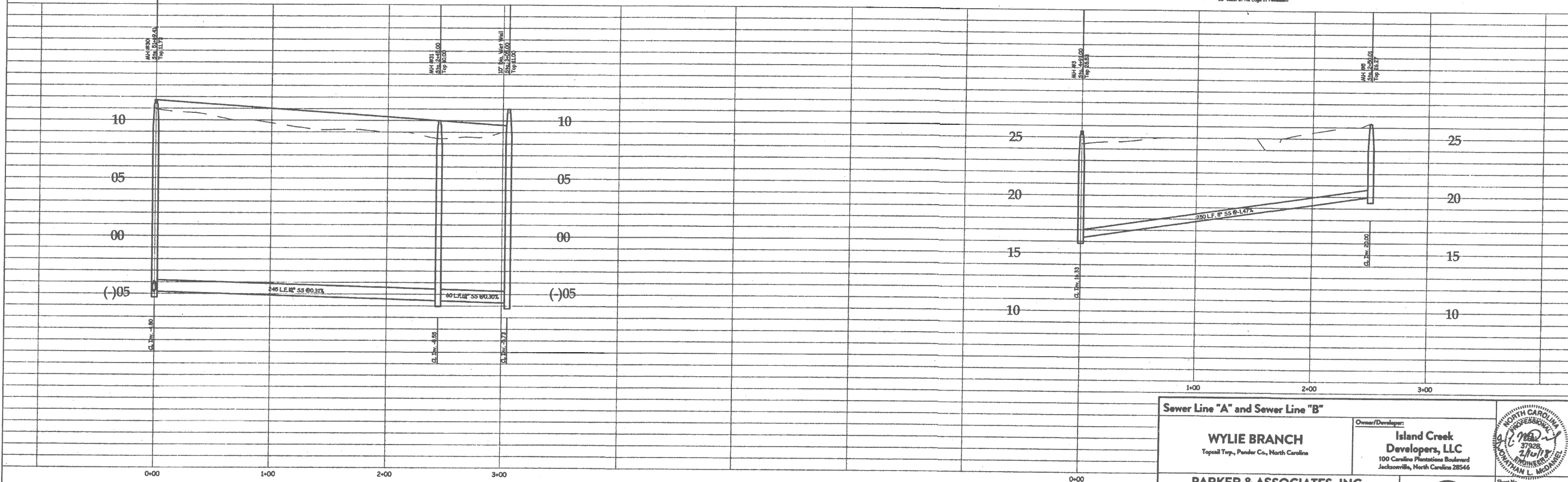

Sewer Line "A" and Sewer Line "B"		
WYLIE BRANCH Topical Top, Pender Co., North Carolina	Owner/Developer: Island Creek Developers, LLC 100 Carolina Plantations Boulevard Jacksonville, North Carolina 28546	
PARKER & ASSOCIATES, INC. Consulting Engineers - Land Surveyors - Land Planners Jacksonville, North Carolina P.O. Box 976 - 28541-0976 306 New Bridge Street - 28540 Phone (910) 455-2414 - Fax (910) 455-3441 Firm License Number F-0104		Sheet No. 29 of 34 Designer: JLM Drafter: BLD Job No: 586190-6892
Date: 02/16/18	Scale: Vertical 1"=40' Horizontal 1"=40'	Planner: WB - Gauding
Disc: Acad #2661		

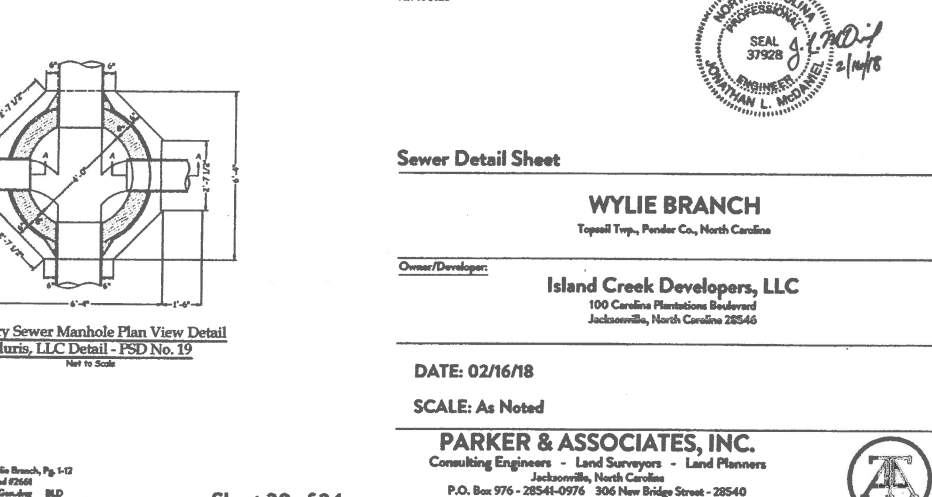
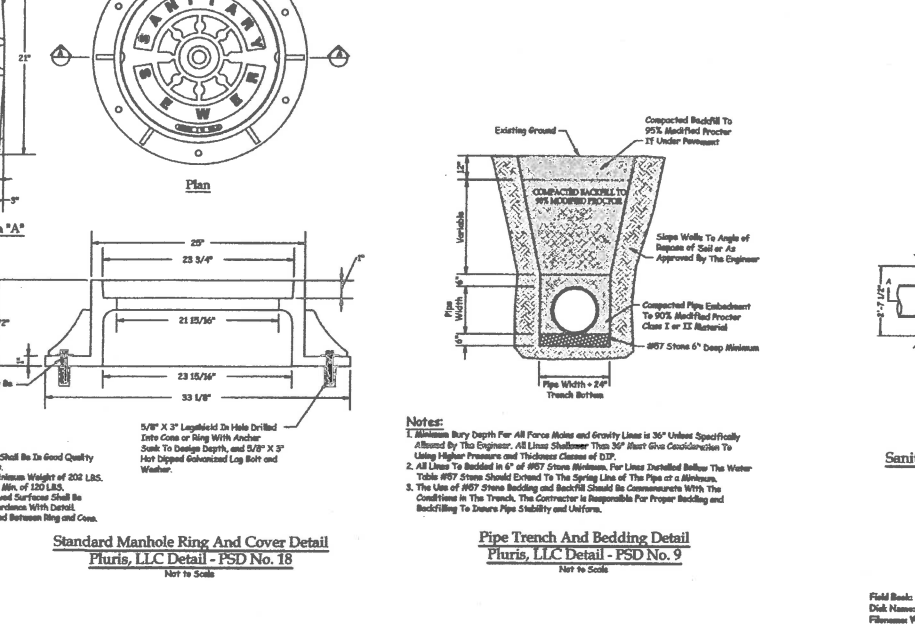
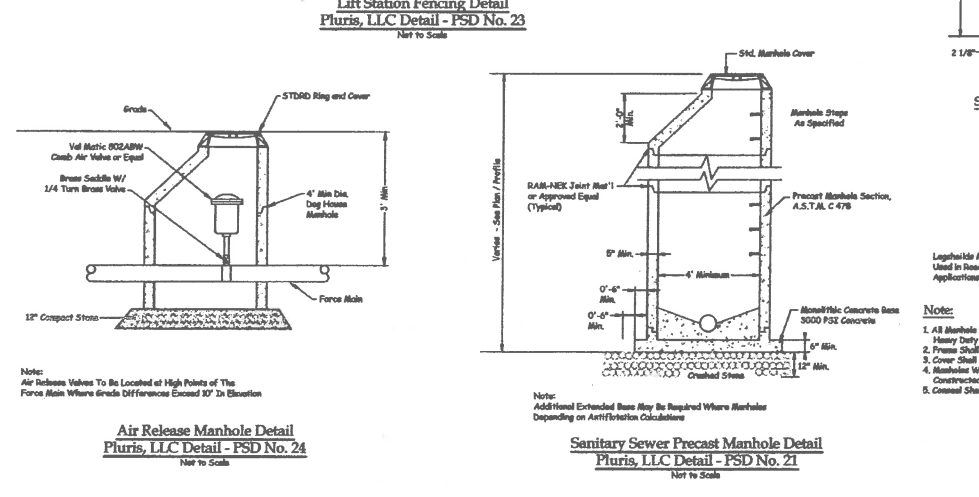
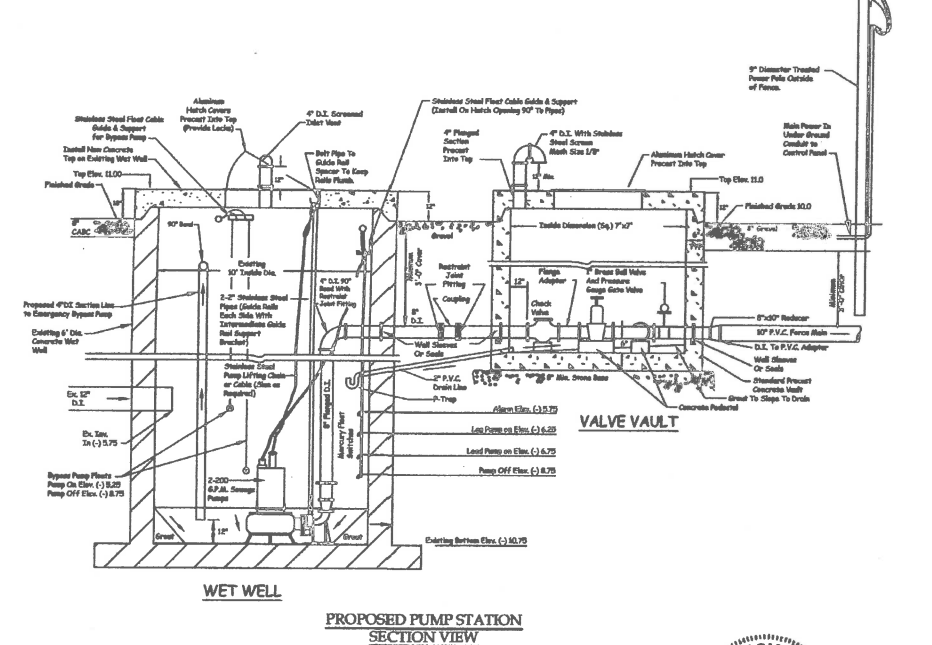
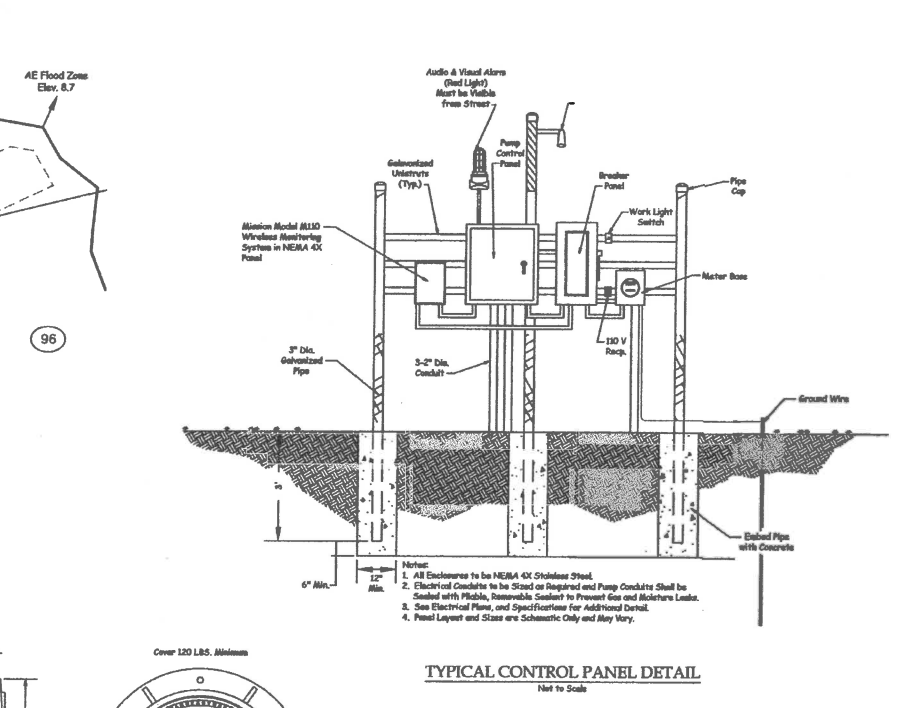
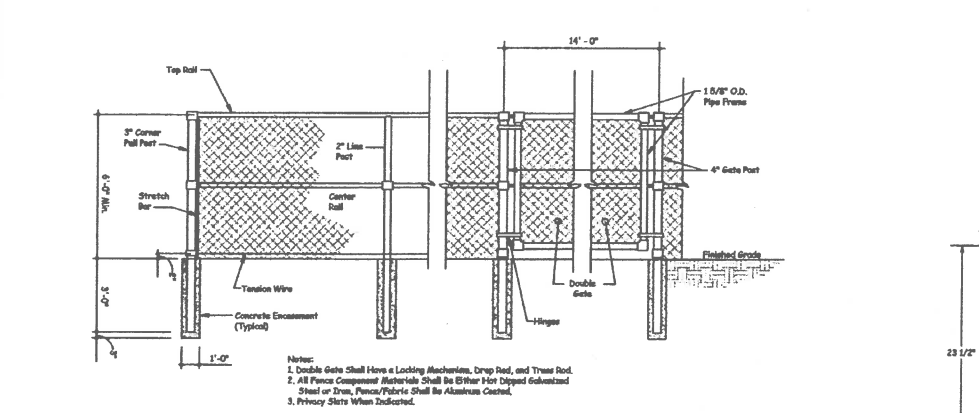
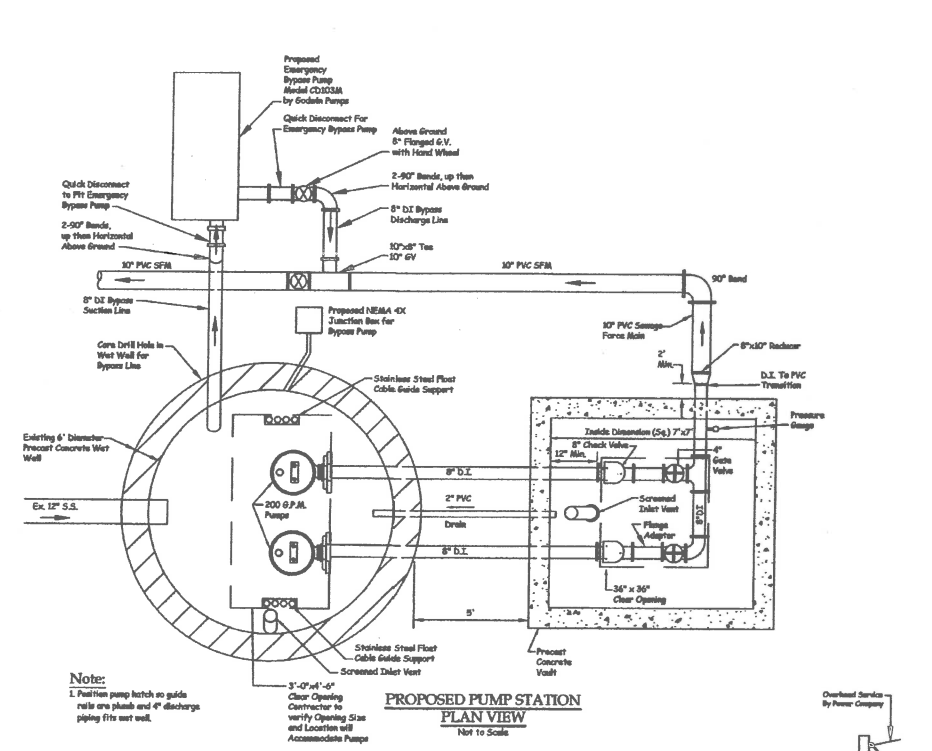
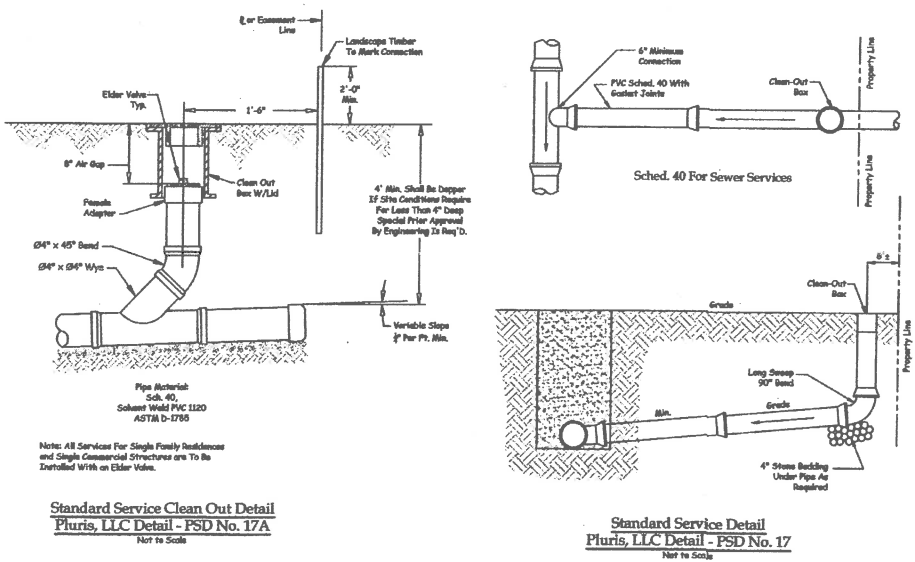
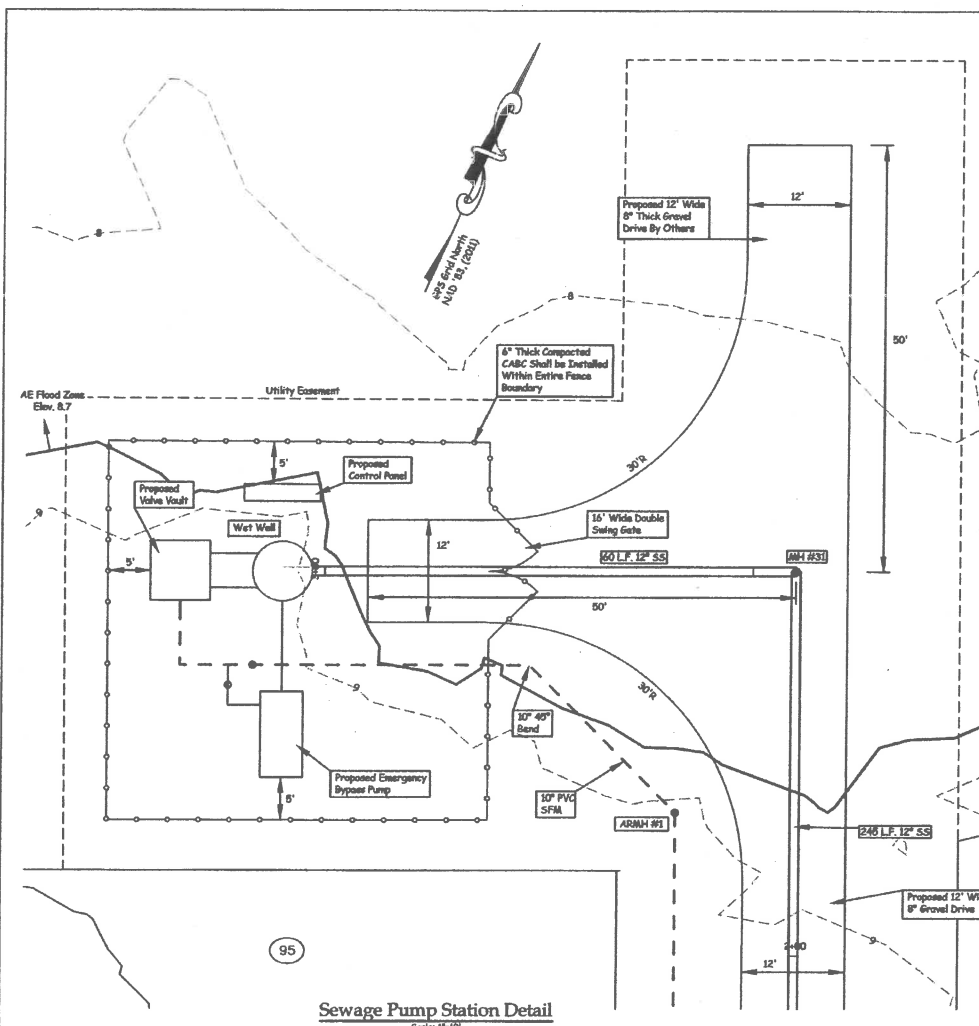

Sewer Detail Sheet

WYLIE BRANCH
Topall Trp., Pender Co., North Carolina

Owner/Developer:
Island Creek Developers, LLC
100 Carolina Plantations Boulevard
Jacksonville, North Carolina 28546

DATE: 02/16/18
SCALE: As Noted

PARKER & ASSOCIATES, INC.
Consulting Engineers - Land Surveyors - Land Planners
Jacksonville, North Carolina
P.O. Box 976 - 28544-0976 306 New Bridge Street - 28540
Phone (910) 455-2414 - Fax (910) 455-3441
Firm License Number: F-0108



Z:\mccord\chd\301218.A\Tried\DWG\WB - Building - 2/16/2018 9:32:14 AM, BLD

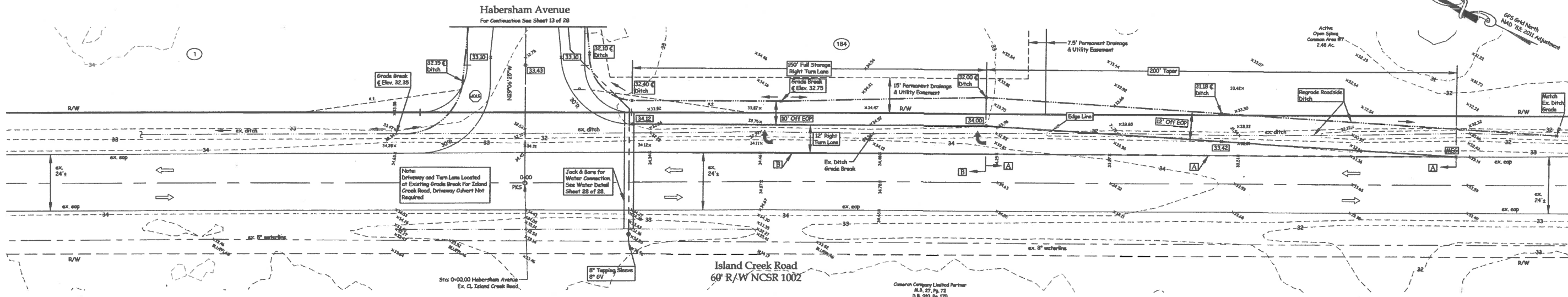

ROADS & DRAINAGE NOTES:

- This streets to be constructed for this project are subject to the Department of Transportation Certification Program and Quality Management Systems Maintenance Version Requirements. The Contractor, at his expense, shall provide test results on 1) Subgrade, 2) Base and 3) Pavement. The Contractor shall insure that all construction and testing is performed in accordance with the N.C. Department of Transportation "Standard Specifications for Roads and Structures", latest edition, 2003 Hot Mix Asphalt Specifications and Manual, and "Quality Management Systems Maintenance Version", and shall report the testing and/or core locations, test method, results and D.O.T. allowable range or tolerance, as applicable. Subgrade shall be tested for density and shall be proofrolled by the testing Engineer or the Engineer or Surveyor who will issue the Final Certification. Base and pavement shall both be tested for density and thickness. If Parker & Associates is administering the construction they must also proofroll the stone. Testing for pavement shall be certified by either a professional Engineer or properly certified QMS technician and shall be in accordance with QMS criteria. Required thickness for this project is as shown on the plans. Note that thickness for widening or turn lanes is greater than that for internal streets.
- Minimum Densities:
Subgrade 100%
Stone Base 100%
SP 9.5A 90%
S 9.5B 92%
I 9.5C 92%
B 2.5B 92%
- Notify the Engineer or Surveyor, who will issue the overall Final Certification, of all phases of Roadway Construction.
- A minimum sight distance of 10'x70' shall be maintained along the right-of-way of all internal intersections.
- 20 foot radii at right-of-way intersections, 30 foot radii at edge of pavement intersections.
- All culverts under streets shall be reinforced concrete per North Carolina Department of Transportation Specifications, unless otherwise specified and/or approved by the Engineer and/or Department of Transportation.
- All materials and practices shall meet North Carolina Department of Transportation Standards.
- For other detailed construction notes, see plan and profiles.

PAVEMENT MARKING SCHEDULE

- A - Mini-slip white 4"x3" @ every 9'
- B - Solid White 4"

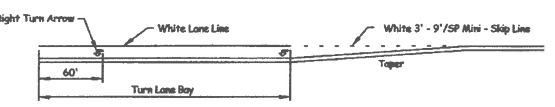

Use the Guidance Shown Above in Conjunction With The Figure 4 Intersection Details
Pavement Markings Turn Lanes (Bays 125-150 Ft.)
NCDOT Detail #1205.05
Not to Scale

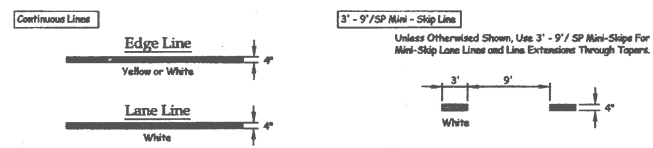

General Notes:

- Use 6" Lane, Edge, and Center Lines on All Full Control of Access Facilities and Other Routes As Directed by The Engineer.
- Lane Lines Indicated as "Wide" on The Roadway Standard Drawings Shall Be At Least Twice The Width of The Normal Lane.
- Gore Lines Shall be Twice The Width of The Normal Lane.

Pavement Markings - Line Types and Offsets
NCDOT Detail #1205.01
Not to Scale

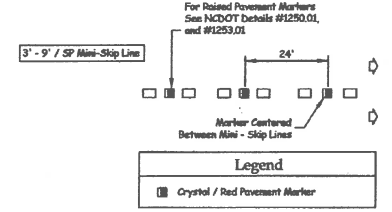

Raised Pavement Markers Installation Spacing
NCDOT Detail #1250.01
Not to Scale

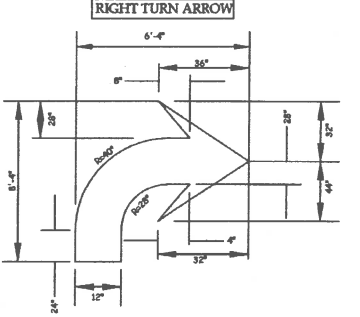

Right Turn Arrow Detail
Not to Scale

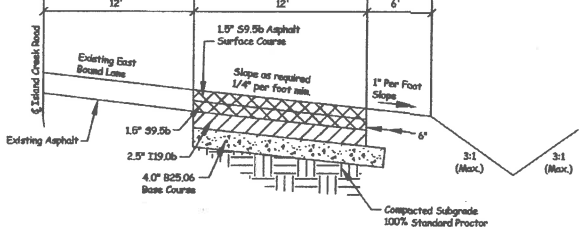

Typical Turn Lane Cross-Section A-A Detail
Not to Scale

Note: Refer to Roadside and Drainage Notes.

Legend:

- Centerline
- Dead Book
- Elev. - Elevation
- esp - Edge of Pavement
- ex - Existing
- GV - Gate Valve
- M.B. - Map Book
- MES - Match Existing Grade
- NCSR - North Carolina Secondary Road
- Pg. - Page
- PKS - PK Nail Set
- R - Radius
- R/W - Right-of-way
- s.t. - 10'x70' Sight Triangle
- Sta. - Station
- x 33.38 - Existing Spot Elevation
- ← - Existing Traffic Flow Arrow Direction (Not Striped)
- - Drainage Flow Arrow
- (184) - Lot Number
- (33.38) - Proposed Spot Elevation
- - Proposed Traffic Flow Arrow
- - Strip Sign
- - Street Sign
- - Existing Ditch/Swale
- - Existing Waterline
- - Proposed Ditch/Swale
- - Proposed Waterline

Turn Lane Notes

- New pavement shall have a 1/4" per foot minimum slope away from centerline. If existing road is crowned, the slope shall continue away from the centerline. In no cases shall the new asphalt be installed without a slope.
 - Construction of turn lane to consist of 4" of Superpave B 25.06 asphalt base, 2.5" of Superpave I19.08 intermediate course and two layers of 1.0" of Superpave S 9.5B asphalt surface course.
 - Strip vegetation from existing shoulder and ditch and mark existing ditch, as needed, and fill with compacted select fill.
 - Subgrade shall be proof rolled and tested prior to installation of base course. All testing shall be conducted by soils engineer. For additional testing requirements, see Roadside and Drainage notes.
 - Edge of existing asphalt shall be saw cut straight then tacked prior to addition of pavement widening.
 - Contractor shall provide traffic control measures per NCDOT requirements.
 - Contractor shall locate all existing underground utilities prior to beginning any construction.
 - Contractor is responsible for the coordination of the relocation of existing utilities with the utility company such as cable tv lines and boxes, phone cables and boxes, power poles and guy wires.
 - All work shall be performed in accordance with N.C. D.O.T. requirements. (See Road & Drainage Notes For Testing Requirements) Particular attention should be paid to securing the appropriate traffic control and safety measures during the course of construction. See Driveway Permit for additional requirements.
 - The contractor is responsible for the relocation of any items such as mail boxes, signs, drive markings, etc. in order to accommodate the new pavement and roadside ditch section.
 - The contractor shall make every effort to minimize disturbances and disruption of adjoining properties. Any disturbed areas, structures, etc. shall be returned to pre-construction conditions. A neat, dressed up project site will be required before final payment is made.
 - Any shrubs or trees within the right-of-way that are necessary to remove to properly construct turn lanes and roadside ditches, shall be removed and properly disposed of. Contractor shall not disturb any shrubs, trees, signs or other structures that are outside the road right-of-way.
 - All disturbed areas shall be seeded within 15 days of completing grading activities in accordance with the following schedule: Apply lime and fertilizer and work into seed bed. Seed mixture shall be distributed uniformly and covered with a clean straw mulch. Mulch shall be crimped or tacked to help hold in place. Material and Application Rates are as follow and are generally considered to be minimums. * Mulch rate to be double if crimped.
- | Material | Application Rate |
|----------------------------------|------------------|
| Lime | 2500 lbs/ac. |
| Fertilizer (10-10-10) | 800 lbs/ac. |
| Mulch | 1.5 tons/ac. |
| Asphalt Tack | 435 gal/ac. max |
| Permanent Seeding | |
| "Rabel" Fescue | 100 lbs/ac. |
| Common Bermuda | 50 lbs/ac. |
| (Mulleed Apr. 1 - Sept. 1) | 75 lbs/ac. |
| Rye Grain (Sept. 1 - Apr. 1) | 50 lbs/ac. |
| German Millet (Apr. 1 - Sept. 1) | 50 lbs/ac. |
| Temporary Seeding | |
| Waco - April 15 | 50 lbs/ac. |
| Koba Lespedeza | 50 lbs/ac. |
| Rye Grain | 100 lbs/ac. |
| April 15 - August 15 | |
| German Millet | 40 lbs/ac. |
| August 15 - Dec. 15 | |
| Rye Grain | 100 lbs/ac. |
- Storm drain piping is not required for this driveway, as the entrance is at an existing grade break.
 - The contractor will be required to install thermoplastic pavement marking lines and symbols and raised reflector pavement markers in accordance with standard N.C.D.O.T. specifications. Contractor shall pre-mark striping plan with chalk and get N.C.D.O.T. approval prior to final striping. Lanes are to be striped 12' wide to provide a 1' paved shoulder.

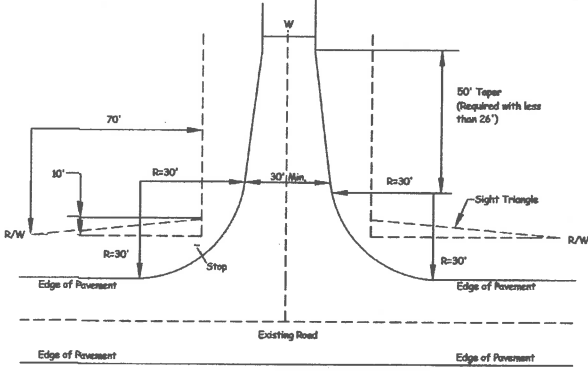
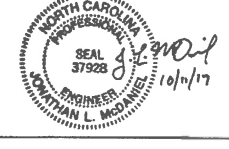

Figure 4
New Residential Collector Road and Existing State Maintained Road
Not to Scale



WYLIE BRANCH
Topical Top., Pender Co., North Carolina

Owner/Developer:
Island Creek Developers, LLC
100 Carolina Plantations Boulevard
Jacksonville, North Carolina 28546

DATE: 06/16/17
SCALE: As Noted

PARKER & ASSOCIATES, INC.
Consulting Engineers - Land Surveyors - Land Planners
Jacksonville, North Carolina
P.O. Box 976 - 28541-0976 306 New Bridge Street - 28540
Phone (910) 455-2414 - Fax (910) 455-3441
Firm License Number: F-0108



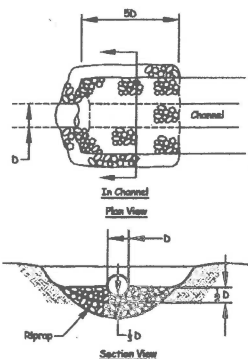

Permanent Riprap Apron
Not to Scale

- Median Stone Diameter = 6" unless otherwise noted on Erosion and Sedimentation Control Plan.
- D = Inside Diameter or width of culvert.
 - Minimum stone thickness to be two times specified stone diameter.
 - Fabric to be installed under riprap located in media.
 - Finished grade of riprap shall be at invert elevation of pipe.

Permanent Riprap Apron
Not to Scale

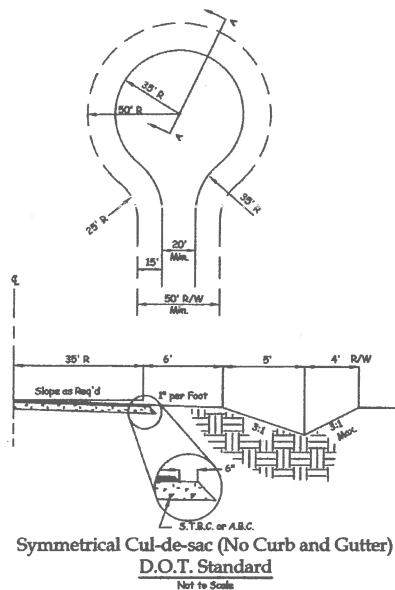

Symmetrical Cul-de-sac (No Curb and Gutter)
D.O.T. Standard
Not to Scale

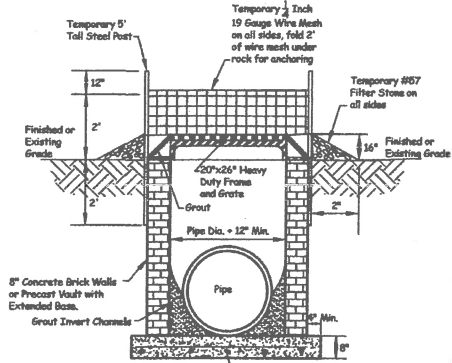

Yard Inlet Catch Basin With Temporary Rock Filter
Not to Scale

- Notes:
- Box to be in accordance with NC DOT Standards (840.25) when in street right of way. Box to be enlarged to accommodate larger or multiple pipes as required.
 - Frames and grates to be Deery Brothers, Inc. CH-8N-18 or approved equal.
 - All sediment, wet, sticky, or yielding soil materials shall be removed and replaced with compacted select fill prior to placing base course.

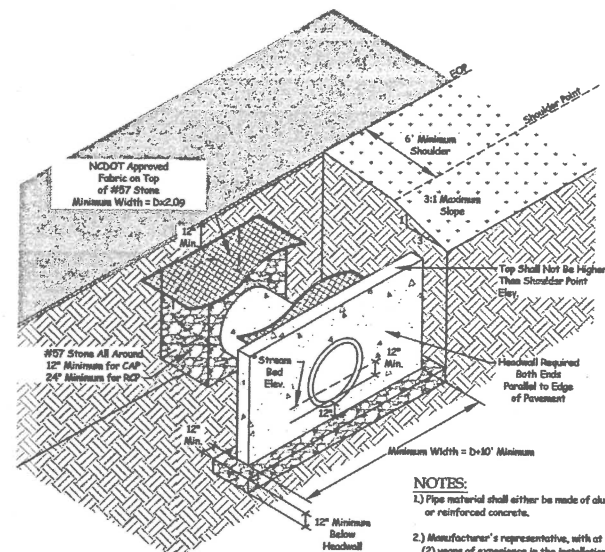

Culvert and Headwall - 54" and Larger Only
(Concrete Pipe and Headwall Shown)
Not to Scale

- NOTES:
- Pipe material shall either be made of aluminum alloy or reinforced concrete.
 - Manufacturer's representative, with at least two (2) years of experience in the installation of the type of structure, is required to provide technical assistance with the assembly of structure and headwalls, as well as be present on site during the installation and backfilling of pipe with headwalls through completion.

- Notes:
- All Concrete to Be 4,000 PSI.
 - Reinforcing Steel Meets ASTM 615 Grade 60 With 2" Min. Clearance.
 - Use Table From Single Headwall With Wings Page 1-HW-W For Dimensions and Reinforcing Steel.
 - All Exposed Edges Chamfered 3/4".
 - Headwall Should be Placed On a Prepared Foundation as Specified by the Engineer.
 - Pipe to Be Grouted Into Headwall At Job Site by Contractor.
 - Compaction of Backfill Materials as Specified by the Engineer.

Contractor/Engineer Supplied Information

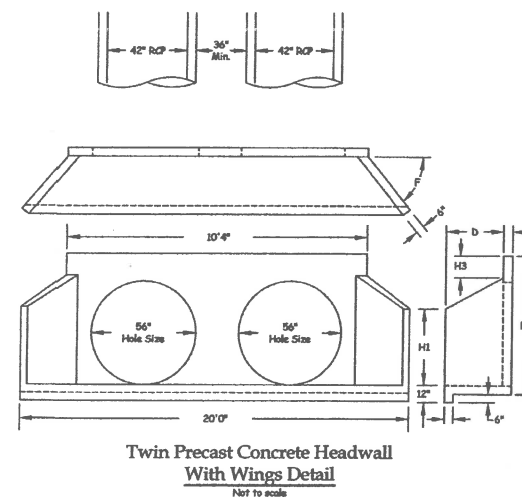

Twin Precast Concrete Headwall With Wings Detail
Not to Scale

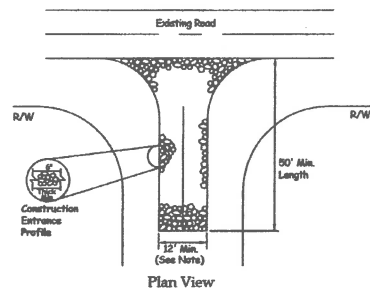

Temporary Stabilized Construction Entrance
Not to Scale

- Construction Specifications:
- Aggregate size - Use 2.5 inch washed stone.
 - Length - As effective, but not less than 80 feet.
 - Thickness - Not less than six (6) inches.
 - Width - Not less than full width of all points of ingress or egress. Minimum of 12'.
 - Install filter fabric under entire forty-foot of the construction entrance.
 - Warning - When necessary, wheels shall be cleaned to remove sediment prior to entrance onto public right-of-way. When washing is required, it shall be done on an area stabilized with crushed stone which drains into an approved sediment trap or sediment basin. All sediment shall be prevented from entering any storm drain, ditch, or watercourse through use of sandbags, gravel, boards or other approved methods.
 - Maintenance - The entrance shall be maintained in a condition which will prevent tracking or flowing of sediment onto public right-of-way. This may require periodic top dressing with additional stone as conditions demand and repair and/or cleanup of any measures used to trap sediment. All sediment, spilled, dropped, washed or tracked onto public right-of-way must be removed.

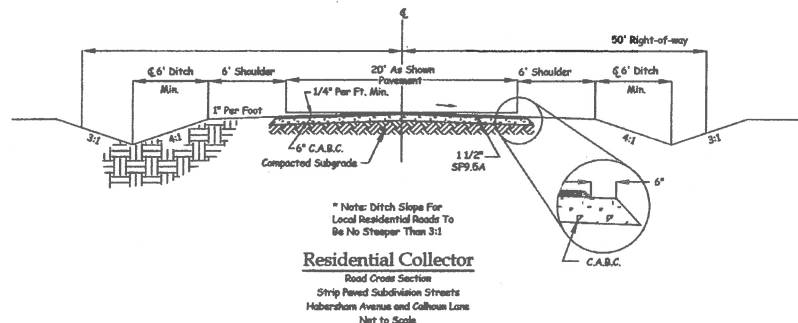

Residential Collector
Road Cross Section
Strip Paved Subdivision Streets
Habersham Avenue and Colburn Lane
Not to Scale

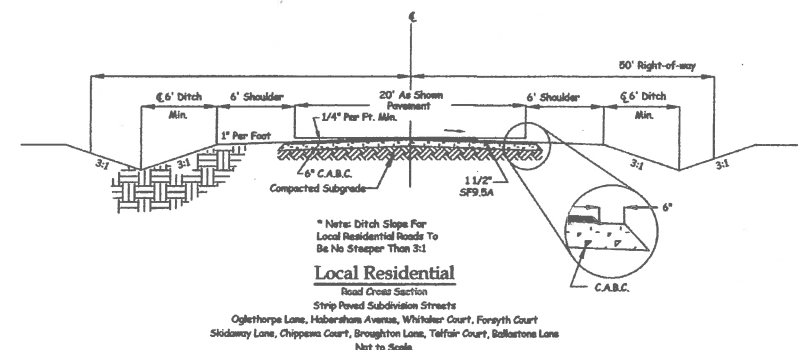

Local Residential
Road Cross Section
Strip Paved Subdivision Streets
Oglethorpe Lane, Habersham Avenue, Whitaker Court, Forsyth Court
Sloansway Lane, Chippewa Court, Broughton Lane, Telfair Court, Ballantyne Lane
Not to Scale

Drainage Pipe Chart

OUTLET PIPE	AREA (Acres)	Q (CFS)	DIAMETER (inches)	GRADE (%)	LENGTH (LF)
A	1.6	5.8	18" RCP	0.83	40
B	0.2	0.7	15" RCP	0.47	32
C	*	63.4	42" RCP	0.00	40
D	*	63.4	42" RCP	0.00	40
E	*	88.0	60" RCP	0.00	40
**F	4.5	16.2	18" RCP	0.62	48 Each
**G	6.4	23.0	24" RCP	0.51	60 Each
H	2.3	7.9	18" RCP	0.54	56
I	1.2	4.1	18" RCP	0.62	48
**J	5.9	20.3	18" RCP	0.62	48 Each
K	17.9	53.7	30" RCP	0.62	48 Each
**L	25.8	66.0	22.5"x36" Arch	0.00	48 Each
M	2.6	8.9	18" RCP	0.62	48
N	1.5	5.2	18" RCP	0.37	54
O	15.0	Note 2	24" RCP	0.00	64
P	15.0	Note 2	4" PVC	0.62	80
Q	1.4	4.8	13.5"x22" Arch	0.62	48
R	2.7	9.3	13.5"x22" Arch	0.62	48
**S	3.6	12.4	13.5"x22" Arch	0.42	48 Each
T	6.8	24.0	24" RCP	0.62	48
U	2.0	6.9	18" RCP	0.62	48

* Combined Area for A-C is 205 acres
** Two Pipes at Road Crossing

Q=CIA
C=0.25 (Pipes C-E)
C=0.40 (All other pipes)
I25=8.6 in/hr (10 min.)
I25=7.5 in/hr (20 min.)
I25=6.4 in/hr (30 min.)
I25=4.2 in/hr (Pipes C-E, T=50 min.)

RCP = Reinforced Concrete Pipe
CFS = Cubic Feet per Second
LF = Linear Feet

- NOTE:
- Contractor shall use invert elevations shown on plans for construction. Grades shown above are rounded.
 - Pipes O and P are outfall pipes from the amenity pond, and were modeled with stage-storage capacity in the pond.

Ditch Calculations Chart for Stormwater

Section	Area (acres)	Q10 (cfs)	Side-Slope	Channel Slope (%)	Velocity (ft/s)	Depth (ft)
1	0.48	1.7	3:1	0.85	1.3	0.7
2	0.95	3.4	3:1	0.57	1.3	0.9
3	4.15	14.9	3:1	0.61	1.9	1.6
4	0.30	1.1	3:1	0.87	1.2	0.6
5	3.92	14.1	3:1	0.42	1.7	1.7
6	0.59	2.1	3:1	0.54	1.1	0.8
7	0.36	1.3	3:1	0.58	1.0	0.7
8	0.50	1.8	3:1	0.70	1.2	0.7
9	1.35	4.9	3:1	0.50	1.4	1.1
10	0.63	2.3	3:1	0.36	1.0	0.9
11	1.02	3.7	3:1	0.45	1.2	1.0
12	1.26	4.5	3:1	1.32	1.9	0.9
*13	15.47	43.8	3:1	0.29	1.9	2.8
14	0.82	2.9	3:1	1.21	1.7	0.8
15	1.50	5.4	3:1	0.67	1.4	1.1
16	***	0.5	3:1	0.36	0.6	0.5
17	1.40	5.0	3:1	0.56	1.4	1.1
18	2.80	10.1	3:1	0.44	1.5	1.5
19	0.64	2.3	3:1	0.50	1.2	0.9

*** - Ditch Flow from hydraulic model on amenity pond outfall.

Q=CIA
C=0.4
I10=9.0 in/hr.
I25=5 min.
I50=10 min. (I10=7.08)

Friction Factors
n=0.05 Grass
n=1.49 R 2/3 @ 1/2
n

- Notes:
- See site plan for typical section locations.
 - Sections selected are worse case sections.



Grading and Drainage Detail Sheet

WYLIE BRANCH
Topsoil Top, Pender Co., North Carolina

Owner/Developer:

Island Creek Developers, LLC
100 Carolina Plantations Boulevard
Jacksonville, North Carolina 28546

DATE: 06/16/17

SCALE: As Noted

PARKER & ASSOCIATES, INC.
Consulting Engineers - Land Surveyors - Land Planners

Jacksonville, North Carolina
P.O. Box 976 - 28541-0976 306 New Bridge Street - 28540
Phone (910) 455-2414 - Fax (910) 455-3441
Firm License Number: F-0108



Field Book: Wylie Branch, Pg 1-12
Disk Name: Am1 #2601
Filename: WB-Grading_BLD
Job No.: 561130-4392

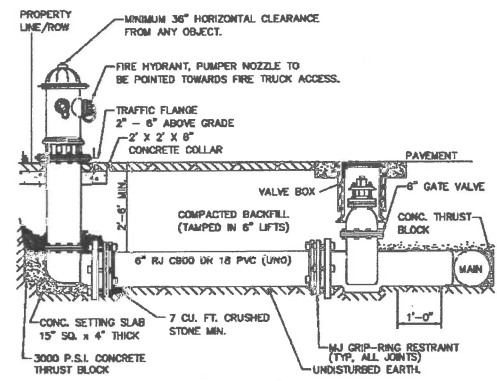

- NOTES:
- FIRE HYDRANTS WILL BE INSTALLED IN TRUE VERTICAL POSITION.
 - FIRE HYDRANTS TO BE LOCATED IN RIGHT-OF-WAY.
 - INSTALL WITH BURY LINE FLUSH TO FINAL GRADE.
 - HYDRANTS TO BE 4" STRENGTH 2700 MEDIUM SUPER CENTURION #473 W/PENDER CO. OPTIONS 0811, OR CLOW MEDALLION WITH STAINLESS STEEL STEMS. HYDRANTS SHALL BE MODULAR STYLE ONLY (BAND).
 - HYDRANTS TO BE RED WITH SILVER CAPS AND BONNET.

Fire Hydrant Assembly Standard Detail
Pender County Utilities (Version #2 - April 2016)

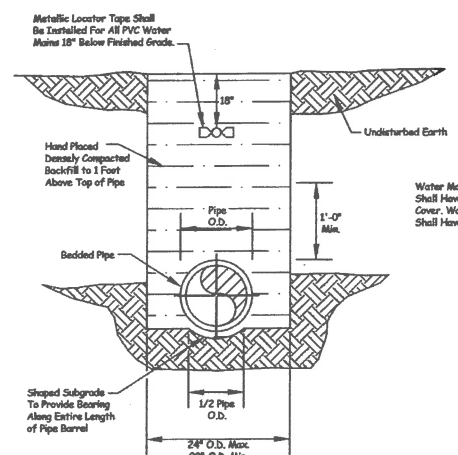

Water Main Embedment Section
Not to scale

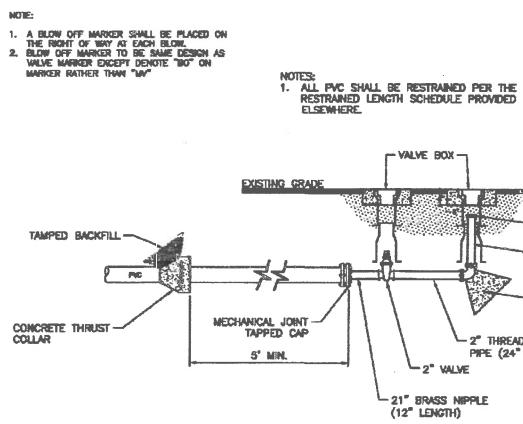

Permanent Blow-Off Assembly Standard Detail
Pender County Utilities (Version #1 - Sept. 2015)

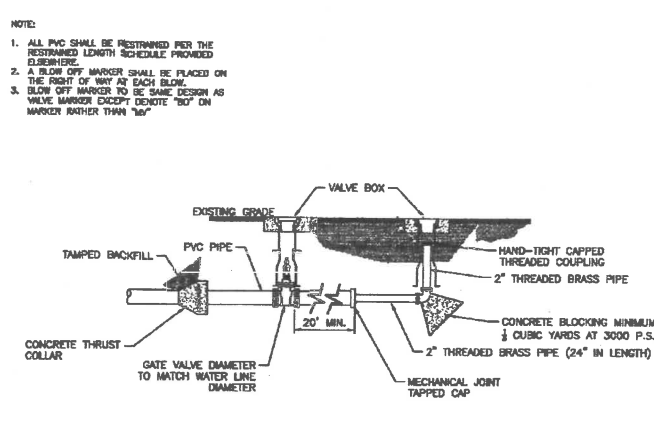

Temporary Blow-Off Assembly Standard Detail
Pender County Utilities (Version #1 - Sept. 2015)

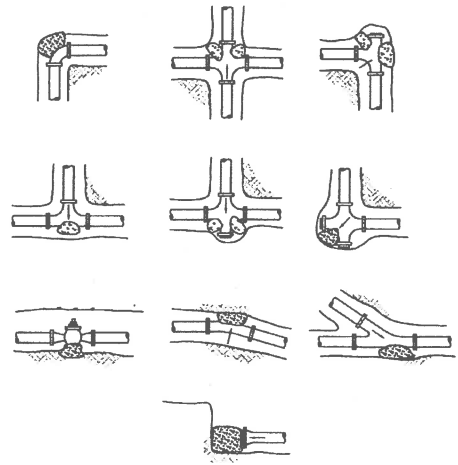

Typical Blocking Details
Not to scale

PIPE DIAMETER (INCHES)	D.I.P.			P.V.C.		
	30"	40"	48"	30"	40"	48"
3"	15"	15"	15"	15"	15"	15"
4"	20"	20"	20"	20"	20"	20"
6"	30"	30"	30"	30"	30"	30"
8"	45"	45"	45"	45"	45"	45"

PIPE DIAMETER (INCHES)	RESTRAINED LENGTH IN FEET FOR REDUCER									
	3"	4"	6"	8"	10"	12"	16"	20"	24"	30"
3"	0	0	0	0	0	0	0	0	0	0
4"	0	0	0	0	0	0	0	0	0	0
6"	0	0	0	0	0	0	0	0	0	0
8"	0	0	0	0	0	0	0	0	0	0

- NOTES:
- PENDER COUNTY STANDARD RESTRAINT METHOD IS 3/4" ROOF BUMP TYPE. ALL IS SPECIFICALLY APPROVED BY PCU IN WRITING.
 - ALL FITTINGS AND JOINTS SHALL BE RESTRAINED JOINT.
 - 1" ABOVE IS GIVEN IN FEET FROM FITTING JOINT.

Fitting Size	Concrete Thrust Blocking Schedule						Concrete Schedule Vertical Beads			
	Blocking Area (Sq. Ft.)			Min. Cu. Yds. Concrete			Min. Cu. Yds. Concrete			
4"	0.8	1.2	0.7	0.3	0.13	0.13	0.13	0.7	0.4	0.3
6"	1.9	2.7	1.5	0.8	0.13	0.13	0.13	1.3	0.9	0.5
8"	3.3	4.8	2.5	1.3	0.13	0.13	0.13	2.5	1.7	0.9
10"	5.2	7.3	4.0	2.0	0.13	0.13	0.13	2.5	2.8	1.5
12"	7.6	10.6	5.9	2.9	0.3	0.4	0.3	5.6	4.0	2.1
16"	13.3	18.9	10.2	5.2	0.5	0.9	0.4	9.8	7.1	3.7
18"	22.5	32.8	17.3	8.9						

Notes:
Areas of blocking and approximate yards of concrete in the above tables are based on the following data: 2000# soil pressure and test pressure at 150 p.s.i. (Blocking area subject to change based on varied soil conditions and shall be done as at the direction of the Engineer).

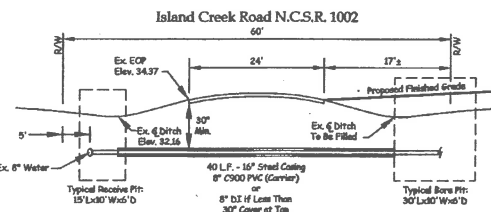

- Notes:
- Contractor to field verify location and depths of existing water mains and any other utilities prior to beginning work.
 - Casing thickness shall be 0.250" per DOT requirements.
 - Casing to extend from ditch to ditch, but no less than 40 LF.
 - Bore and receive pit shall be minimum of 1' H per 1' V depth away from the edge of pavement.
 - Use 8" ductile iron or angle tapping sleeve and use elbows as needed to maintain 30° of cover at south side of Island Creek Road.

Water Bore Detail
Not to scale

Restrained Joint Table Standard Detail
Pender County Utilities (Version #1 - Oct. 2015)

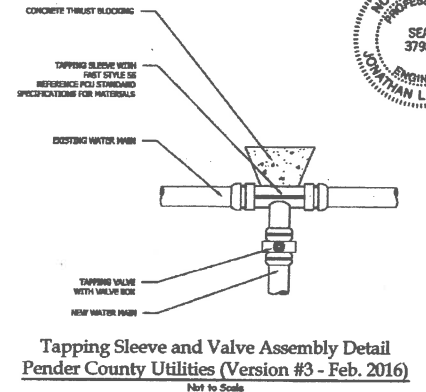

Tapping Sleeve and Valve Assembly Detail
Pender County Utilities (Version #3 - Feb. 2016)

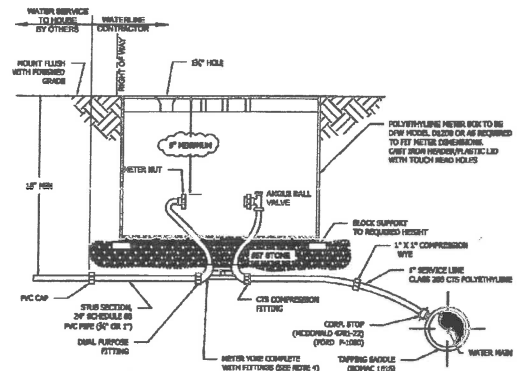

- NOTES:
- CONTRACTOR SHALL PLACE METER BOX IN NON-TRAFFIC AREA ONLY.
 - ALL TAPS TO BE MADE ON THE TOP QUARTER OF THE WATER MAIN.
 - CONTRACTOR SHALL CENTER METER VOICE IN METER BOX (BY MEASURING 24\"/>

Water Service (3/4\"/>

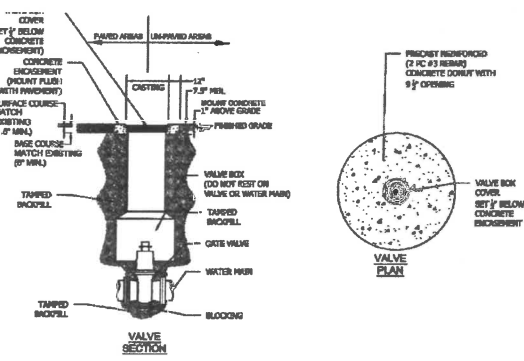

Valve Installation Standard Detail
Pender County Utilities (Version #3 - June 2016)

Water Detail Sheet

WYLIE BRANCH
Topical Tap, Pender Co., North Carolina

Owner/Developer: Island Creek Developers, LLC
100 Carolina Plantations Boulevard
Jacksonville, North Carolina 28546

DATE: 06/16/17
SCALE: As Noted

PARKER & ASSOCIATES, INC.
Consulting Engineers - Land Surveyors - Land Planners
Jacksonville, North Carolina
P.O. Box 976 - 28541-0976 306 New Bridge Street - 28540
Phone (910) 455-2414 - Fax (910) 455-3441
Firm License Number: P-0108

